

Features

- The trainer is used for teaching the student to understand the principle of recording and audio playback system in cassette recorder.
- The cassette recorder and two loud speakers are mounted on a special frame panel with sliding tray which allows the main printed circuit board to be exposed for easy working.
- The cassette recorder has a transparent cover to make the circuit board viewable from outside. The transparent cover can be easily opened for access to circuit and all test points.
- The front panel is printed with block diagram for a good visualization of the trainer.
- Equipped with fault simulation point and fault LED indicators. If one of the fault points is triggered, a corresponding LED is electronically activated, indicating that the fault is active. The LED indicators can be de-activated for students to learn the troubleshooting techniques.
- To get realistic fault, points of fault simulation are created according to common problems happened in the real world (recording and playback mode), which make teaching troubleshooting techniques close to reality.
- Complete with comprehensive experiment manual book to guide student step by step in conducting experiments.

Cassette Recorder Trainer

PT 93111



Specification

- **Main Power Supply**
 - Input voltage (AC) : 220V / 50Hz
- **Fault System**
 - Fault simulator : 25 electronic faults system
- **Connection terminal 4mm leads for Fault Pen simulator**
- **Test point 2mm leads for fault simulator, LED Control and Master RESET**
- **Cassette Tape Recorder**
 - Mechanic : Auto stop mechanism
 - Power Amplifier : Stereo / 2 x 20W / 8Ω
 - Input termination : Auxiliary/Line IN and Microphone
 - Output termination : Line OUT and Loudspeaker
 - Control function : Volume, Loudness, AVC & Balance
 - Audio level indicator : Bar LED display
 - Equalizer : 5 graphics channels
- **Loudspeaker**
 - Input Impedance : 2 x 8Ω/100W (max.)
- **Microphone**
 - Microphone type : Dynamic
 - Frequency response : 100 – 15000 Hz
 - Output impedance : 600Ω (+/-20%) at 1kHz
 - Connector type : cannon with low noise cord
- **Blank Cassette**
 - Duration : 90 minutes
 - Position IEC type : Normal Recording

Covered Topics

- EE01001E Operation of a Cassette Recorder
- EE01002E Block Circuit of a Magnetic Recorder
- EE01003E The Head (Magnetic Head)
- EE01004E Reproduction of an Audio Signal
- EE01005E Initial Magnetization and Erasure
- EE01006E Checking The Bias/Erase System
- EE01007E Fault Finding at The ALC (Automatic Level Control) System
- EE01008E The AVC (Automatic Vocal Changer) System
- EE01009E Equalizer System
- EE01010E Microphone Amplifier

Training Panel System

PT 93111 Cassette Recorder Trainer consists of		
Cat. No.	Description	Qty.
PTE93111	Cassette Tape Recorder Trainer	1 set
GSC 701	Blank Cassette	1 pc
GSC 702	Dynamic Microphone	1 pc
KAL 99/40-100	Connecting Lead 100cm, Yellow	1 pc
E01S-01E	Experiment Manual Book	1 pc
E01T-01E	Theory Book	1 pc



Transparent cover to make the circuit board viewable from outside

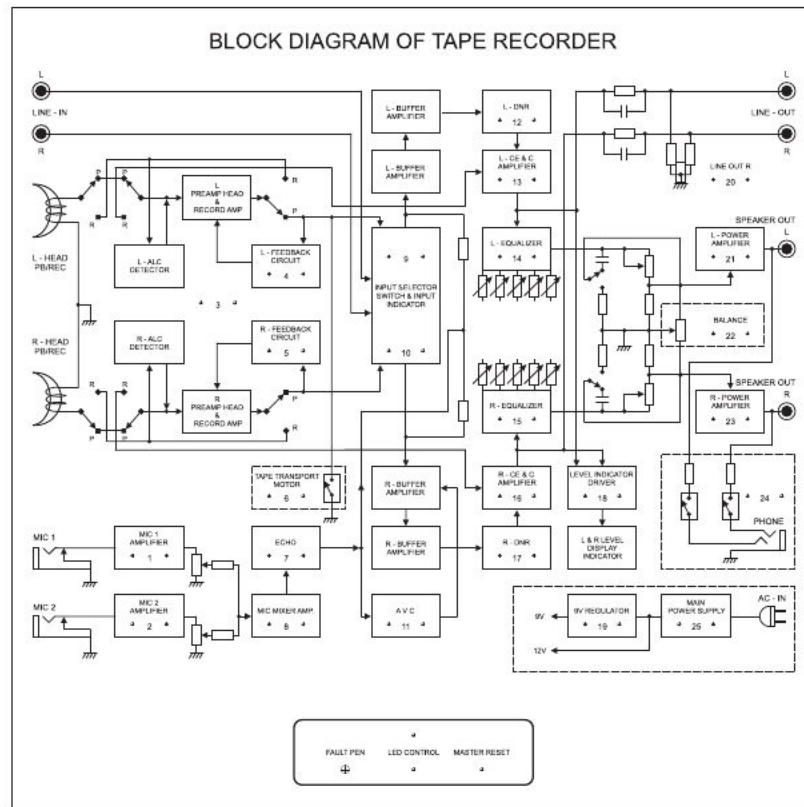

Block Diagram of Tape Recorder Type: DAT-59C

Features

- The trainer can be used for laboratory classroom experiment or as a teaching aid for student to carry out realistic practical work in mono or stereo audio system.
- This trainer is designed for comfortable analysis and application of audio measurement techniques.
- The system consist of modular block to enable the student to learn Audio System in modular way. The panel type construction is easy to handle by student when conducting the experiment.
- Each Module is equipped with protector circuit.
- All inputs and outputs on each panel are equipped with 4 mm sockets for easy connection.
- Complete with comprehensive Experiment manual book to guide student step by step in conducting experiments.

Audio System Trainer

PT 980501



Covered Topics

- EE08001E Introduction of Audio System
- EE08002E Input Selector and Pre Amplifier Function
- EE08003E Microphone Pre Amplifier
- EE08004E Signal Mixing Process
- EE08005E Tone Control Function
- EE08006E Power Amplifier
- EE08007E Measuring Distortion on Power Amplifier

Specification

- **Power Supply [PTE-032-01]**
 - Input voltage : AC 220V / 50Hz
 - Output voltage : DC +15V and -15V
 - Output current : 2A
- **Input Selector [PTE-032-02]**
 - Input source : Tape, Tuner & CD or other Auxiliary
 - Input terminal type : RCA Jack stereo
- **Stereo Pre Amplifier [PTE-032-03]**
 - Universal Pre Amplifier module to various signal source.
 - Contain of : Microphone Amplifier circuit, Mixer circuit, and Filter circuit
 - Operation mode : Mono & Stereo
 - Input voltage : +15VDC
 - Frequency response : 20Hz – 50kHz
- **Stereo Tone Control [PTE-032-04]**
 - Control function : Volume, Bass, Treble and Balance
 - Operation mode : Mono & Stereo
 - Input voltage : +15VDC
 - Input impedance : 120k Ω
 - Frequency response : 20Hz – 90kHz
- **Stereo Power Amplifier [PTE-032-05]**
 - Power type : OCL
 - Power output : 20W / 4 Ω
 - Operation mode : Mono & Stereo
 - Input voltage : +15VDC and -15VDC
 - Input impedance : 40k Ω
 - Load impedance : 4 Ω / 8 Ω
- **Loudspeaker [PTE-032-06]**
 - Input impedance : 8 Ω / 20W
 - Mode switch : Internal & External speaker
- **Dummy Load [PTE-032-07]**
 - Input impedance : 8 Ω / 25W (2 channel)
- **Audio Level Meter [PTE-032-08]**
 - Display Mode : BAR or DOT (switchable)
 - Input Voltage : +15VDC and -15VDC

Training Panel System

PT 980501 Audio System Trainer consists of		
Cat. No.	Description	Qty.
PTE-032-01	Power Supply	1 pc
PTE-032-02	Input Selector	1 pc
PTE-032-03	Stereo Pre Amplifier	1 pc
PTE-032-04	Stereo Tone Control	1 pc
PTE-032-05	Stereo Power Amplifier	1 pc
PTE-032-06	Loudspeaker	2 pcs
PTE-032-07	Dummy Load	1 pc
PTE-032-08	Audio Level Meter	1 pc
FLS 20.02/097	Connecting Cross	25 pcs
KAL 99/30-050	Connecting Lead 50cm, Blue	20 pcs
KAL 99/10-050	Connecting Lead 50cm, Black	2 pcs
KAL 99/20-050	Connecting Lead 50cm, Red	2 pcs
KAL 99/30-075	Connecting Lead 75cm, Blue	2 pcs
E08S-01E	Experiment Manual Book	1 pc
GSN 240	TPS Frame 600mm	1 set

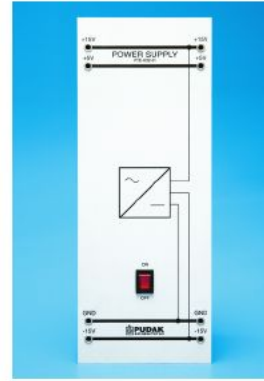

Power Supply
PTE-032-01

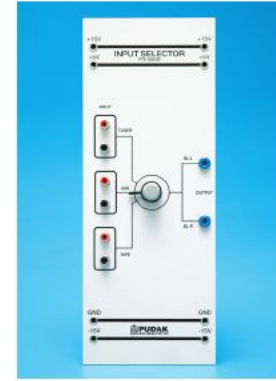

Input Selector
PTE-032-02

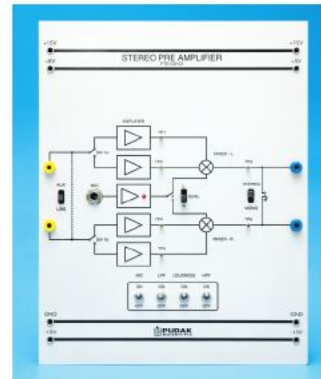

Stereo Pre Amplifier
PTE-032-03

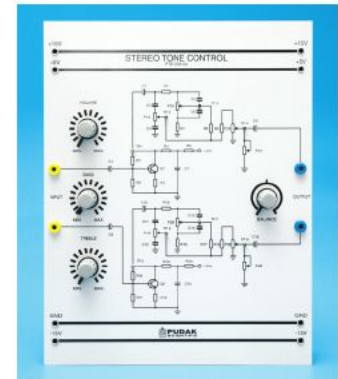

Stereo Tone Control
PTE-032-04



Loud Speaker
PTE-032-06

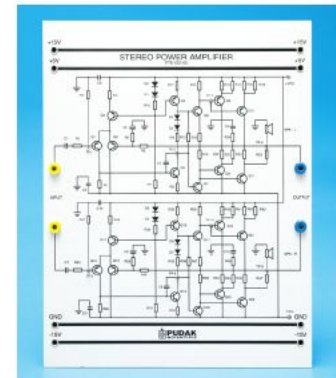

Stereo Power Amplifier
PTE-032-05

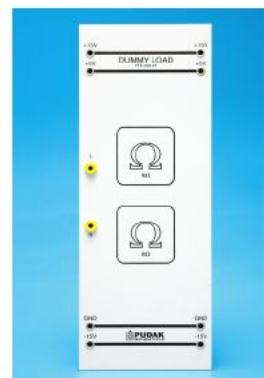

Dummy Load
PTE-032-07



Audio Level Meter
PTE-032-08

Specifications and illustrations are subject to change without prior notice

Features

- The Radio Trainer is designed to teach and demonstrate the principles of communication radio, specifically in radio broadcast-band reception system.
- The system come as a compact desktop system with clearly block schematic diagram printed on upper side. It enables the student to learn and practice receiving AM/FM radio system easily. The constructions of desktop type are easy to handle by student and placed on experiment-table when conducting experiments.
- Provided with 25 realistic faults simulation to customized in doing experiment and troubleshooting of radio receiver.
- The LED fault indicators placed on each block diagram and lights on with fault accrued. The lights as indicating the fault occurs are able to disable, for examination purpose.
- Complete with comprehensive Experiment manual book to guide the student step by step in conducting experiments.

Radio Trainer

PT 99325D

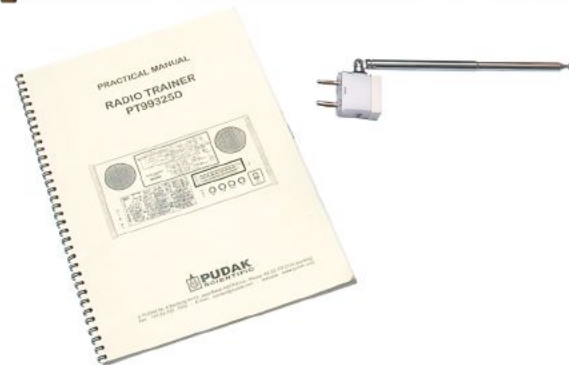

Covered Topics

- TE09001E AM RF Amplifier, Mixer and Oscillator
- TE09002E AM IF Amplifier
- TE09003E Detector and AGC
- TE09004E FM Receiver Front end: FM RF Amplifier, Mixer and Oscillator
- TE09005E FM IF Amplifier, Detector and AFC
- TE09006E Multiplex Stereo Demodulator
- TE09007E Tone Control
- TE09008E Audio Amplifier

Specification

• Radio receiver system	: Integrated Circuit
• Frequency coverage	: FM : 88 – 108 MHz AM : MW : 530 – 1600 kHz SW : 5.0 – 18 MHz
• Sensitivity	: 1mV (approx)
• IF frequency	: FM : 10.7MHz AM : 455kHz
• Audio output power	: 2 × 2 watts
• Tone control	: Bass & Treble
• Fault simulation system	: 25 faults selectable with push-button and electronic switch
• Test point	: 25 Test Points on PCB component side
• Power requirements	: 220VAC / 50Hz

Training Panel System

PT 99325D Radio Trainer consists of		
Cat. No.	Description	Qty.
PT 99325D	Radio Trainer	1 unit
FEL 220 02	Telescopic Antenna	1 pc
T09S-01E	Experiment Manual Book	1 pc



Analog Scale and Control Panel



Fault Simulation System



Main Board with Test Points

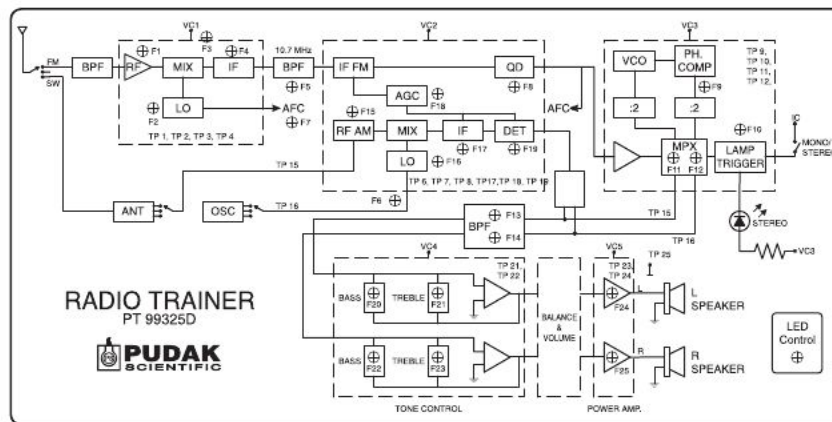

Block Diagram of Radio Trainer

Specifications and illustrations are subject to change without prior notice

Features

- The Digital Satellite Receiver Trainer is designed for the teaching and learning of basic knowledge on installation and device settings of a complete satellite receiver.
- Block diagram of the Digital Satellite Receiver is included that can be used as installation guide.
- In training, students can immediately practice to install, assemble and set up the device as well as field trials, so that the students can understand the working principles of each stage of the satellite television receiver systems.
- The Digital Satellite Receiver Trainer is excellent in providing knowledge on basic skills regarding:
 - Installation and setup of Feedhorn Low Noise Block (LNBF) Converter;
 - Parabolic Antenna Alignment based on location
 - Installation and alignment of a parabolic dish reflector and the connection from the LNB to the receiver using a coaxial cable;
 - Provided with software CD to guide the satellite signal receiving antenna alignment
 - The setting and set up program on the receiving device both manually and automatically
- Equipped with supporting facilities work stored on shelves covered with a safety lock
- Include Experiments manual.

Covered Topics

- EE05001 Satellite Communication Systems
- EE05002 Digital Satellite Receiver System
- EE05003 Introduction of Basic Components Digital Satellite Receiver
- EE05004 Parabolic Dish Antenna Installation Digital Satellite Receiver
- EE05005 Parabolic Antenna Actuator Installation
- EE05006 Positioner Module Operation
- EE05007 Setting Position and Direction Antenna Digital Satellite Receiver

Digital Satellite Receiver Trainer

PT 010501



Specification

- **Main Power Supply**
 - Input voltage : 220V/50Hz (AC)
- **Low Noise Block Feed Horn Down Converter**
 - LNBF C-band
 - LNBF Ku-band
- **Connection Terminals**
 - LNB IN / OUT : F connector (male & female)
 - Audio/Video IN/OUT: RCA male to female with cable
 - Coaxial Cable Type : RG6 / 75 ohm /Length of 2 x 10 meters
- **Digital Satellite Equipment (DiSEqC) Receiver**
 - Digital Satellite Receiver HD
 - Frequency operation: 950 - 2150MHZ
 - Fully DVB-S2 Std Digital TV Reception Compliant
 - Storage Capacity: up to 2000 TP/4000 Channels
 - Support HDTV / SDTV MPEG2/MPEG4
 - Support Signal Modulated in QPSK/8PSK
 - Support USB 2.0; DiSEqC 1.2 1.0/DiSEqC
 - IN/OUT mode : LNB IN; Audio L/R(OUT); CVBS (OUT)
: Coaxial (OUT); HDMI (OUT); RS232 & USB (IN)
- **Display Monitor Reception**
 - Size Display : 7"
 - Display type : TFT LCD Monitor
 - Screen mode : High Resolution Wide Screen Display
 - Resolution : 480 x 234 Pixels
 - System Mode : NTSC / PAL
- **Digital Satellite Equipment (DiSEqC) Positioner + Actuator**
 - Dual mode; Anti-Noise circuit
 - Has 60 programmable memories Position
 - Equipped with a series of short circuit & overload protection
 - Actuator motor with limit switch
- **Digital Satellite Equipment (DiSEqC) Switch**
 - Mode : 2 x 1 (DiSEqC Switch 1.2)
- **Antenna:**
 - 6 Feet Solid Dish Parabolic
 - Prime Focus Type Assemble with standbase



Operation of Digital Satellite Receiver

Training Panel System

PT 010501 Digital Satellite Receiver Trainer consists of

Description	Qty.
Digital Satellite Receiver Trainer	1 set
Remote Control Digital Satellite Receiver	1 pc
Remote control Dish Antenna Positioner	1 pc
LNBF Converter C-Band	1 pc
LNBF Converter Ku-Band	1 pc
Actuator for Dish Antenna Positioning	1 pc
Solid Dish Antenna 6 feet with standbase	1 set
Coaxial cable RG6 / 75 ohm with F-Male conn 10 meter	2 rolls
Coaxial cable RG6 / 75 ohm with F-Male conn 40 cm	2 pcs
Coaxial cable RG6 / 75 ohm with F-Male conn 60 cm	2 pcs
Power cable for Actuator control, 10 meter	1 roll
RCA Audio Video adapter with cable	1 pc
Satellite finder	1 pc
Compass	1 pc
Waterpass / Angel Meter	1 pc
Wrench / Ring no.10, 12, 14,17, 19 @1 pc	1 set
Screwdriver (+) and (-) @1 pc	1 set



Actuator for Dish Antenna Positioning



Accessories for Digital Satellite Receiver Trainer



Installation of LNB C and Ku-Band on Dual Scalar Ring

BLOCK DIAGRAM OF DIGITAL SATELLITE RECEIVER

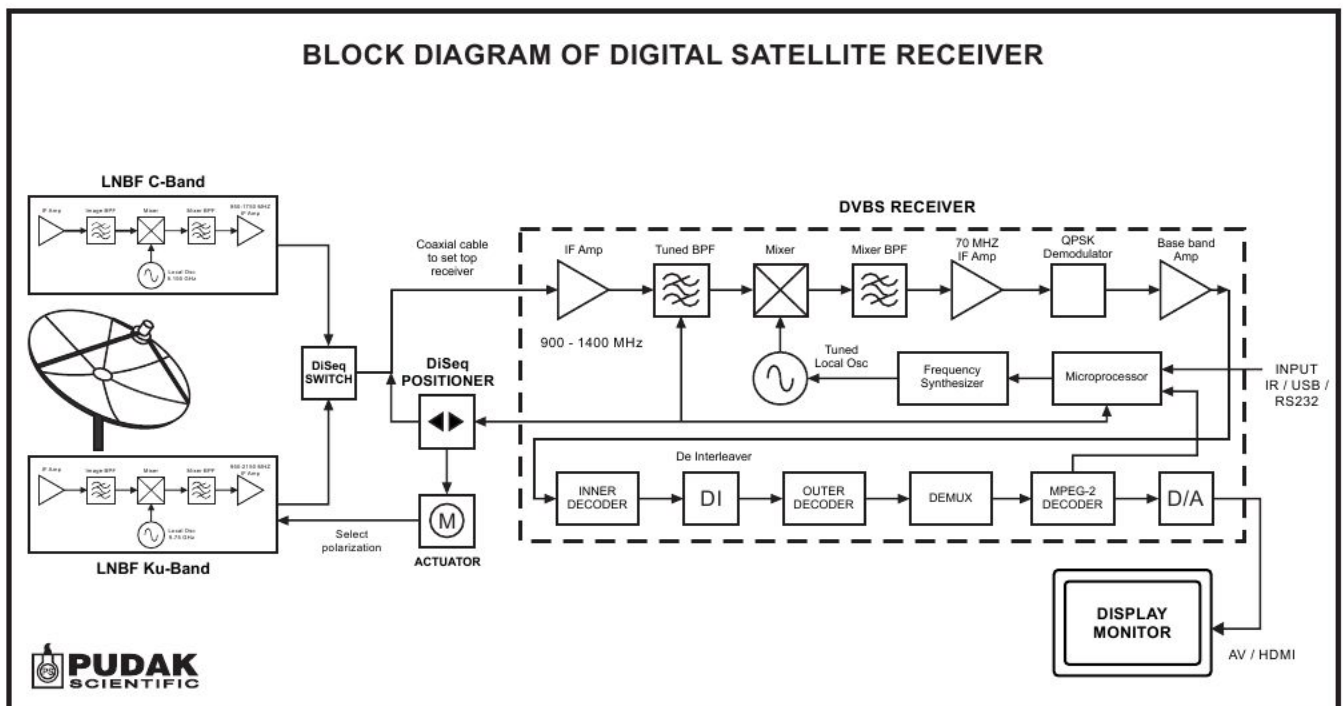

Specifications and illustrations are subject to change without prior notice

Features

- Closed Circuit Television Trainer is designed as teaching aid to give basic knowledge of installation, device settings and maintaining of CCTV System
- The training device is designed with using the common 4-channel CCTV System mounted on panel, and CCTV cameras formed as sparates modules that are inserted in the frame panel system.
- A schematic block diagram of basic 4-channel CCTV system is printed on panel, that can clearly be used as installation guide.
- Students can directly carry out practice setting up CCTV connections, setting up the DVR, practicing surveillance techniques via pc / laptop or Smartphone as well as field trials.
- Closed Circuit Television Trainer excellence to provide knowledge of basic skills regarding:
 - knowledge to determine the types and functions of different cameras;
 - Installing the CCTV Cameras and operation DVR System, record, searching recording data, and backup recording data.
 - Setup the DVR, Setting and configure CCTV stand alone system;
 - Setting Networking CCTV System with router and WIFI; and internet.
- Equipped with supporting WIFI-router and RJ45 connecting facilities.
- Include Experiment manual.

Covered Topics

- | | |
|-----------|--|
| ▪ EE06001 | Basical of CCTV Camera Systems |
| ▪ EE06002 | Signal Transmission and Connecting cable of CCTV System |
| ▪ EE06003 | Schematic Block diagram of CCTV System |
| ▪ EE06004 | Installing Camera and DVR for Stand alone Operation |
| ▪ EE06005 | Setup and operating DVR |
| ▪ EE06006 | Recording, Searching, and backup record data; |
| ▪ EE06007 | Camera Positioning of surveillance area |
| ▪ EE06008 | Setup DVR to Networking using pc/Laptop |
| ▪ EE06009 | Setup DVR Networking by using Ruter LAN and using WIFI connection. |
| ▪ EE06010 | Monitoring surveillance area via Smartphone |

Specification

- **Main power supply**
 - Input voltage (AC): 220V/50Hz
 - Output (DC) 4 x 12V/2A
- **Monitor System**
 - 7" TFT LCD Monitor,
 - High Resolution Wide Screen Display with Resolution: 480 x 234 Pixels,
 - System Mode: NTSC / PAL
 - Audio-Video Input

CCTV Trainer

PT 991225



- **Dome Camera:** Sensor 1/3" Sharp, Resolution 420TVL, 3.6mm Lens , IR 24pcs LED 25M, Metal Design
- **Box Camera:** Sensor 1/3" Sony; Resolution 420TVL, 0.8 Lux min illumination, Aluminium alloy design
- **Pinhole Camera:** Sensor 1/3" Sony, Resolution 420TVL, 3.7mm Lens, Aluminium Alloy design
- **Outdoor IR Camera:** 1/3" Sony CCD, Resolution 420TVL, 3.6mm Lens, 32 IR LED up to 30M, Metal case
- **DVR:**
 - System Mode: NTSC / PAL (auto detect)
 - Video Compression Format: H.264
 - Composite and VGA output simultaneously
 - Image Quality Setting: SUPER BEST / BEST / HIGH / NORMAL
 - 4Ch Video input, 4 Ch Audio input
 - Multiplex Operation: Live display / record / playback / backup / network operations
 - Menu & Setup: Panel, USB Mouse & IR Remote Control
 - Recording Mode: Manual / Timer / Motion / Alarm / Remote
 - Pre-alarm Recording
 - Motion Detection Area: 16 x 12 grids/ch; 3 adjustable Sensitivity parameters for accurate detection
 - Quick Search: Time / Motion / Alarm
 - System auto recovery after power failure
 - Backup Device: USB 2.0 flash drive / Network
 - Ethernet: 10/100 Base-T. Supports remote control and live view via Ethernet
 - Network Protocol : TCP/IP, PPPoE, DHCP and DDNS
 - Hard Disk Storage: One Sata 1TB

Training Panel System

PT 991225 CCTV Trainer consists of:

Description	Qty.
PTE-061-01 Power Supply	1 pc
PTE-061-02 Dome Camera	1 pc
PTE-061-03 Box CCD Camera	1 pc
PTE-061-04 Pinhole Camera	1 pc
PTE-061-05 Outdoor IR Camera	1 pc
PTE-061-06 4 Ch DVR with 1TB Storage HDD and 7 Inch LCD Monitor	1 set
DVR Remote Control	1 pc
USB Mouse	1 pc
Wireless Router - 3 10/100 LAN Port + Power Supply	1 set
Video & DC Power Connecting Lead 75 cm	4 sets
Video & DC Power Connecting Lead 200 cm	2 pcs
Video & DC Power Connecting Lead 400 cm	2 pcs
Video & DC Power Connecting Lead 1200 cm	1 pc
Video Coaxial cable RG6/750hm BNC - BNC Video connecting Lead 60cm	1 pc
LAN Cable RJ-45 to RJ45 145cm	2 pcs
Audio Connecting Lead RCA-RCA 60cm	1 pc
Frame Standard H	1 pc
Manual Experiment book	1 pc



CCTV Cameras in
Modular Panel System



DVR 4ch Input



7" LCD Monitor System

BLOCK DIAGRAM OF CCTV RECEIVER

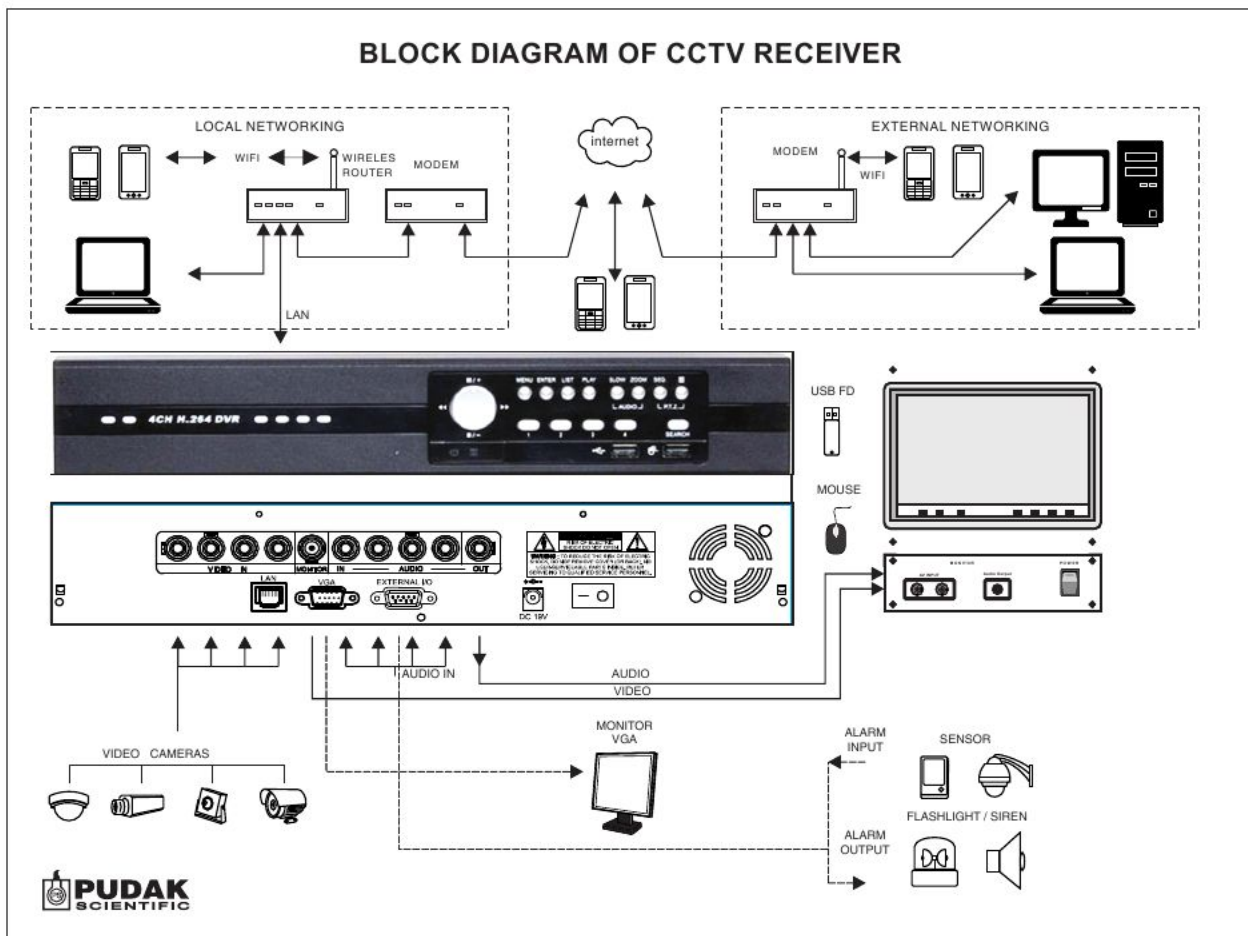

Specifications and illustrations are subject to change without prior notice

Features

- The trainer is designed to teach the fundamental of data transmission using fiber optic.
- Various methods of data transmission, analog and digital data transmission experiment are included in the trainer to demonstrate that the fiber optic can handle various data types and methods of transmission.
- The plastic fiber optic used is robust and thus ideal for student experiments.
- The system consist of modular block to enable the student learn the fundamental of data transmission using fiber optic in modular way. The panel type constructions are easy to handle by student when conducting the experiment.
- All inputs and outputs on each panel are equipped with robust 4-mm sockets for easy connection.
- Complete with comprehensive experiment manual book to guide student step by step in conducting experiments.

Opto Electronic Trainer

PT 93225

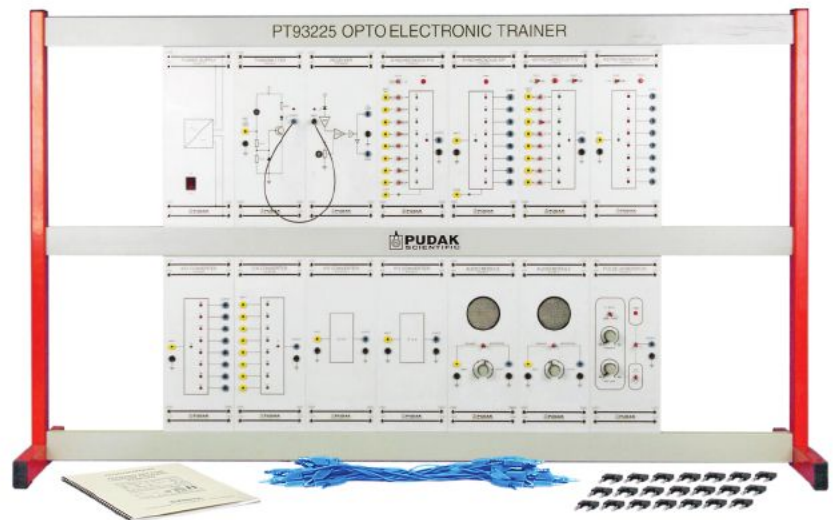

Covered Topics

- TE01001E Application of Fiber Optic in Data Communication
- TE01002E Transmission and Reception of Binary Data Using Synchronous Method
- TE01003E Transmission and Reception of Binary Data Using Asynchronous Method
- TE01004E Transmission of Data in The Form of DC Voltage
- TE01005E Transmission of Audio Signals Through Fiber Optic Using Asynchronous Method

Specification

- **Transmitter [PTE-003-01]**
 - Wide band frequency
 - Input TTL & CMOS
- **Receiver [PTE-003-02]**
 - Wide band frequency
 - Output TTL & CMOS
- **Synchronous P/S [PTE-003-03]**
 - 8 bits data
 - External & internal data source
 - LED's are included for indicating the input state
- **Synchronous S/P [PTE-003-04]**
 - 8 bits data
 - LED's are included for indicating the output state
- **Asynchronous P/S [PTE-003-05]**
 - 8 bits data
 - External & internal data source
 - LED's are included for indicating the input state
- **Asynchronous S/P [PTE-003-06]**
 - 8 bits data
 - LED's are included for indicating the output state
- **A/D Converter [PTE-003-07]**
 - Enable the function of type of A/D Conversion to be examined
 - Range of Conversion 0 – 5 volt with output generated 8 bits digital
 - LED's are included for indicating the input and output state of conversion
- **D/A Converter [PTE-003-08]**
 - Enable the function of type of D/A Conversion to be examined
 - The module includes a source of reference voltage with accuracy 20mV per LSB and 256 Combinational of Logic Digital
 - LED's are included for indicating the input and output state of conversion

Continue >>

Training Panel System

>> Specification Continued

- **V/F Converter [PTE-003-09]**
 - Input voltage: 0 – 5VDC
 - Output frequency : 20 – 20kHz
 - Center frequency : 100kHz

- **F/V Converter [PTE-003-10]**
 - Input frequency : 20 – 20kHz
 - Output voltage : 0 – 5VDC
 - Center frequency : 100kHz

- **Audio Module [PTE-003-11]**
 - The module can be used as speaker or microphone function

- **Pulse Generator [PTE-003-12]**
 - Direct output or inverted output
 - Clock frequencies provides 2 range, 2 – 300Hz and 100 – 16kHz
 - Generated edge positive pulse or edge negative pulse with toggle switch
 - Single shot trigger available
 - Voltage input : +15VDC & -15VDC

- **Power Supply [PTE-003-13]**
 - Voltage input : 220VAC, 50Hz
 - Output voltage : +15VDC, 1A
+5VDC, 1A
-15VDC, 0,5A

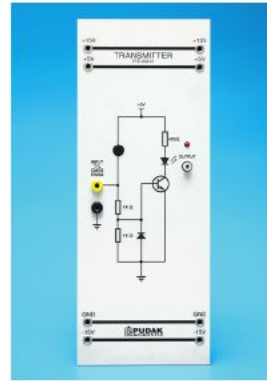

Transmitter
PTE-003-01

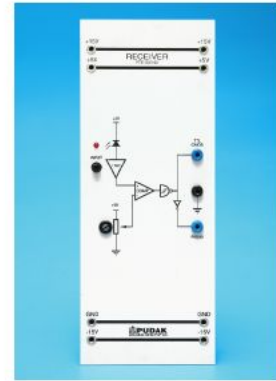

Receiver
PTE-003-02

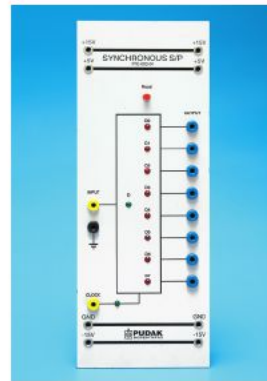

Synchronous S/P
PTE-003-04

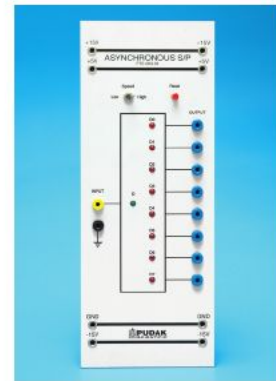

ASynchronous S/P
PTE-003-04

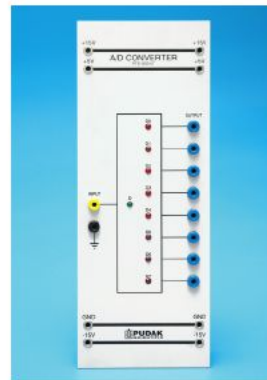

A/D Converter
PTE-003-07



V/F Converter
PTE-003-09



Audio Module
PTE-003-11



Pulse Generator
PTE-003-12

PT 93225 Opto Electronic Trainer consists of		
Cat. No.	Description	Qty.
PTE-003-01	Transmitter	1 pc
PTE-003-02	Receiver	1 pc
PTE-003-03	Synchronous P/S	1 pc
PTE-003-04	Synchronous S/P	1 pc
PTE-003-05	Asynchronous P/S	1 pc
PTE-003-06	Asynchronous S/P	1 pc
PTE-003-07	A/D Converter	1 pc
PTE-003-08	D/A Converter	1 pc
PTE-003-09	V/F Converter	1 pc
PTE-003-10	F/V Converter	1 pc
PTE-003-11	Audio Module	2 pcs
PTE-003-12	Pulse Generator	1 pc
PTE-003-13	Power Supply	1 pc
POG 477 01	Plastic Fiber Optic, length 50cm	1 pc
FLS 20.02/097	Connecting Cross	60 pcs
KAL 99/30-050	Connecting Lead 50cm, Blue	40 pcs
KAL 99/10-050	Connecting Lead 50cm, Black	10 pcs
KAL 99/20-050	Connecting Lead 50cm, Red	10 pcs
T01S-01E	Experiment Manual Book	1 pc
GSN 245	TPS Frame 1200mm	1 set

Specifications and illustrations are subject to change without prior notice

Features

- The Basic Analog Communication Trainer is designed to teach, present and demonstrate the principles of analog communication system.
- The trainer consists of modular block to enable the student to learn analog communication system in modular way. The panel type constructions are easy to handle by student when conducting the experiment.
- All input and output on each panel are equipped with robust 4-mm sockets for easy connection.
- Complete with comprehensive Experiment manual book to guide the student step by step in conducting experiments.

Basic Analog Communication Trainer

PT 93227

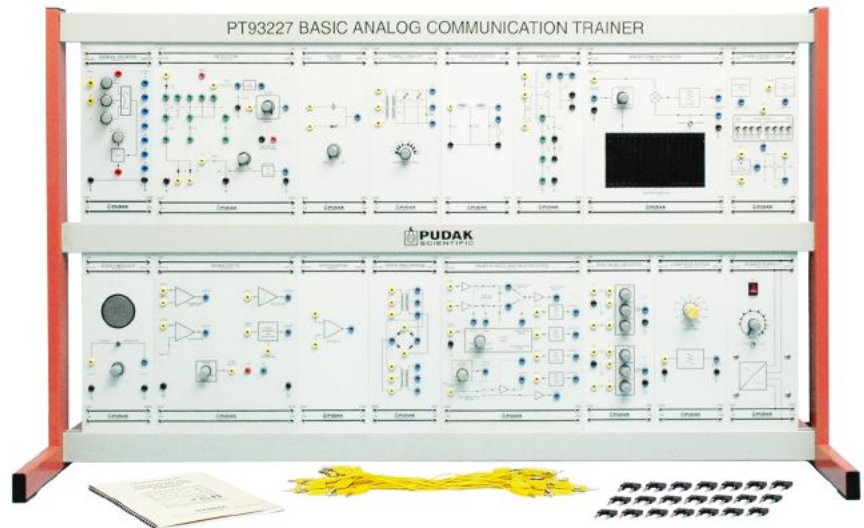

Covered Topics

- TE02001E Signal Source
- TE02002E Tuned Circuit
- TE02003E Filter
- TE02004E Amplifier
- TE02005E Amplitude Modulation
- TE02006E Balanced Modulator
- TE02007E Demodulation
- TE02008E AM Super Heterodyne Reception
- TE02009E Frequency Modulation
- TE02010E Sample and Hold
- TE02011E Phase Locked Loop
- TE02012E Delta Modulation

Specification

- **Power Supply [PTE-011-17]**
 - Input voltage : 220V, 50Hz
 - Output voltage : +15VDC, 1A
-15VDC, 1A
Variable 1.5 – 20 VDC, 1A
- **Signal Source [PTE-011-01]**
 - Input voltage : +15V, -15V, Variable 2.2 – 20 VDC
 - Output frequency : f low = 100Hz - 3kHz
f high = 1kHz - 1MHz
 - Output Vpp at 0dB : 1.8Vpp (approx.)
- **Detector [PTE-011-02]**
 - Input voltage : +15V, -15VDC
 - Circuit configurable : AM detection, FM detection includes AGC, AFC
- **Filter [PTE-011-03]**
 - Circuit configuration : X-tal and C phasing
- **Tuned Circuit [PTE-011-04]**
 - Range : 400 – 550 kHz
- **Passive Filter [PTE-011-05]**
 - Cut-off frequency : 3kHz (approx.)
 - Circuit configuration : LPF
- **Superhet [PTE-011-06]**
 - Input voltage : 15VDC
 - Frequency coverage : 600kHz – 1.6MHz
 - IF frequency : 460kHz (±15% via Variable Capacitor)
- **Amplifier [PTE-011-07]**
 - Input voltage : -15VDC
- **Waveform Synthesizer [PTE-011-08]**
 - Input voltage : +15V, -15V
 - Clock frequency range : 800 – 4000 Hz
 - Output frequency range : 50 – 250 Hz
- **Phase Locked Loop [PTE-011-09]**
 - Input voltage : +15V
 - VCO : 100 – 200 kHz (approx.)
 - Frequency reference : 1kHz

Continue >>

Training Panel System

>> Specification Continued

- **Sigma Delta [PTE-011-10]**
 - Input voltage : +15V, -15V
 - Internal clock rate : Variable 30 – 250 kHz
 - Output pulse train : Bi-Directional

- **Integrator [PTE-011-11]**
 - Input voltage : +15V, -15V

- **Diode Ring Bridge [PTE-011-12]**
 - Configuration : Passive circuit with ferrite toroid transformer and bridge diode

- **Sample Hold and Multiplexer [PTE-011-13]**
 - Input voltage : +15V, -15V

- **Double Balanced Modulator [PTE-011-14]**
 - Input voltage: +15V, -15V
 - Balanced Input : Manually controllable

- **Low Pass Filter [PTE-011-15]**
 - Input Voltage : +15V, -15V
 - Frequency cutoff : 90 – 4200 Hz variable in 11 Steps

- **Audio Module [PTE-011-16]**
 - Input voltage : +15V, -15V
 - Dual function : Speaker or Microphones
 - Output power (as Speaker) : 2W

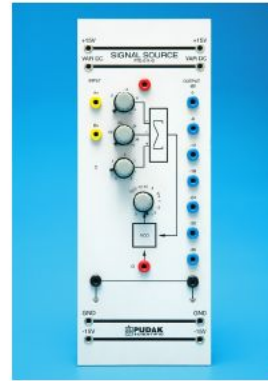

Signal Source
PTE-011-01

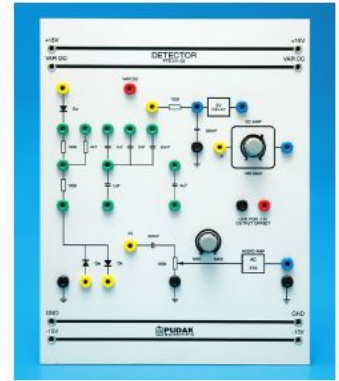

Detector
PTE-011-02

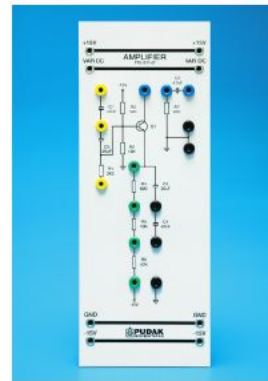

Amplifier
PTE-011-07

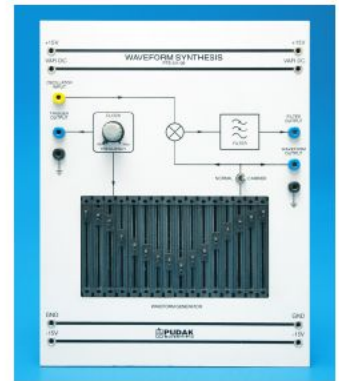

Wave Form Synthesizer
PTE-011-08

PT 93227 Basic Analog Communication Trainer consists of

Cat. No.	Description	Qty.
PTE-011-01	Signal Source	1 pc
PTE-011-02	Detector	1 pc
PTE-011-03	Filter	1 pc
PTE-011-04	Tuned Circuit	1 pc
PTE-011-05	Passive Filter	1 pc
PTE-011-06	Super Het	1 pc
PTE-011-07	Amplifier	1 pc
PTE-011-08	Waveform Synthesizer	1 pc
PTE-011-09	Phase Locked Loop	1 pc
PTE-011-10	Sigma Delta	1 pc
PTE-011-11	Integrator	1 pc
PTE-011-12	Diode Ring Bridge	1 pc
PTE-011-13	Sample Hold Multiplexer	1 pc
PTE-011-14	Double Balanced Modulator	1 pc
PTE-011-15	Low Pass Filter	1 pc
PTE-011-16	Audio Module	2 pcs
PTE-011-17	Power Supply	1 pc
FLS 20.02/097	Connecting Cross	40 pcs
KAL 99/40-030	Connecting Lead 30cm, Yellow	20 pcs
KAL 99/10-050	Connecting Lead 50cm, Black	2 pcs
KAL 99/20-050	Connecting Lead 50cm, Red	2 pcs
KAL 99/30-075	Connecting Lead 75cm, Blue	6 pcs
T02S-01E	Experiment Manual Book	1 pc
GSN 245	TPS Frame 1200mm	1 set

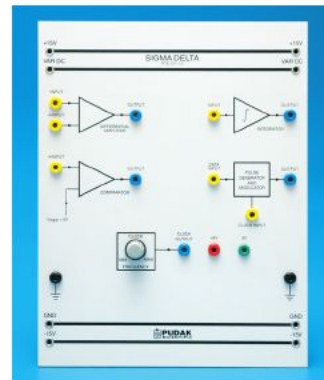

Sigma Delta
PTE-011-10

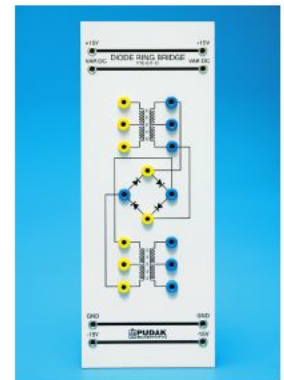

Diode Ring Bridge
PTE-011-12

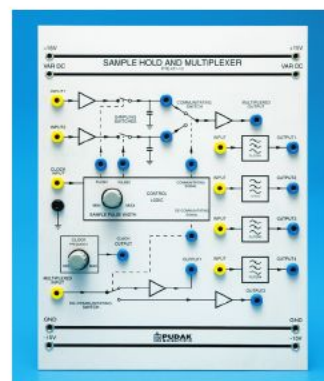

Sample Hold and Multiplexer
PTE-003-13

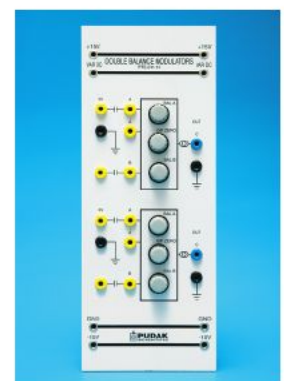

Double Balance Modulators
PTE-003-14

Specifications and illustrations are subject to change without prior notice

Features

- The trainer is designed as teaching aid in studying electronic communication, especially in digital communication.
- The trainer can be used to teach fundamental, concepts theory and practicing in digital communication.
- Panel type, easy to handle.
- All input and output on each panel are equipped with robust 4-mm sockets for easy connection.
- Connecting leads, connecting cross and other connecting device are supplied in sufficient quantity to do all experiments.
- Complete with comprehensive Experiment manual book to guide the student step by step in conducting experiments.

Basic Digital Communication Trainer

PT 93229

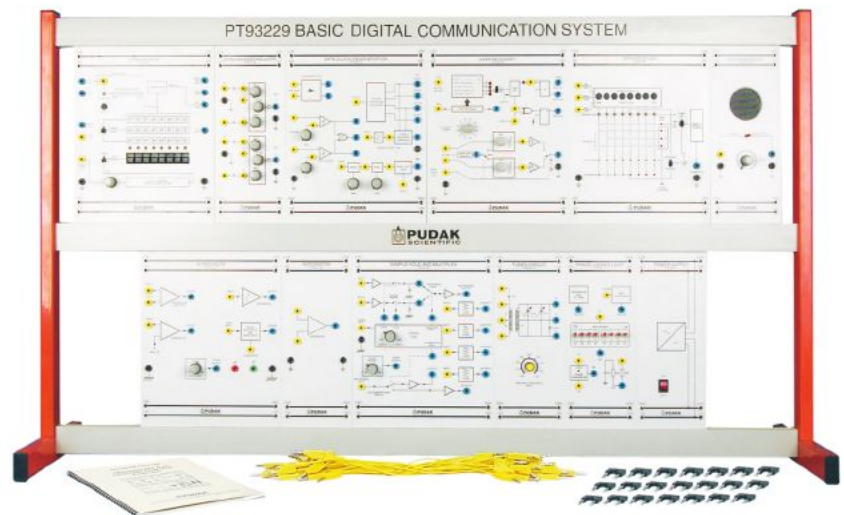

Covered Topics

- TE03001 Introduction to Digital Signaling
 - Building a Data Source
 - The Transmission of Analog Signals Digitally
 - Obtain the Analog Output
 - Testing the Simple Telephone
- TE03002 Dealing With Noise in Digital System
 - Rejection of Existing Noise
 - Error Detection
 - Error Correction
- TE03003 Clock Regeneration (NRZ Data)
 - Bit Clock Generator
 - The Effect of the Clock
 - Transmission of Recognition Word
- TE04004 Amplitude Shift Keying (ASK)
 - Simple ASK Detection
 - Detection of ASK (With Suppressed Carrier)
- TE04005 Sample and Hold
 - The Effect of Sampling Pulse Width
 - The Relation Between Sampling and Signal Input Frequency
 - Pulse Amplitude Modulation (PAM), Pulse Width Modulation (PWM) & Pulse Position Modulation (PPM)
- TE04006 Aliasing and Multiplex Signaling
 - Aliasing
 - Time Division Multiplex
- TE04007 Delta and Sigma Delta Modulation
 - Testing the Pulse Generator
 - Delta Modulator
 - Sigma Delta Modulation
- TE04008 Phase Locked Loop
 - Phase Locked Loop with Internal Reference Frequency
 - Phase Locked Loop with External Reference Frequency

Specification

- **Data Source [PTE-001-01]**
 - The module can generate 8 bits data in 3 data format:
 - 8 bits data NRZ
 - 7 bits data NRZ and 1 odd parity
 - Hamming code
 - Analog input
- **Double Balance Modulator [PTE-001-02]**
 - There are 2 sets of balanced modulators in a module
- **Data Clock Regeneration [PTE-001-03]**
 - The module can regenerate clock for synchronize transmitter and receiver
 - The module can reject noise from the system and correcting data error
- **Data Recovery [PTE-001-04]**
 - Part of data clock regeneration can reconstruct bit clock & word clock from data flow
- **Data Receiver [PTE-001-05]**
 - The module can receive and display the data which is sent from Data Source (PTE-001-01)
 - Error data simulation is available
 - Analog output
- **Audio Module [PTE-001-06]**
 - The module can be used as a speaker or a microphone function
 - Output 2W
- **Sigma Delta [PTE-001-07]**
 - Provide delta modulation and sigma delta modulation
- **Integrator [PTE-001-08]**
 - Combine with Sigma Delta (PTE-001-07) module to form delta and sigma delta modulation
- **Sample Hold and Multiplexer [PTE-001-09]**
 - The module use to demonstrate sampling method
 - The module use to demonstrate simultaneous transmission of two signals through one channel using multiplexer
- **Tuned Circuit [PTE-001-10]**
 - Resonant frequency: 1.43 – 1.80 MHz

Continue >>

Training Panel System

>> Specification Continued

- **Phase Locked Loop [PTE-001-11]**
 - Output frequency : 100 – 199 kHz
 - Can be set digitally
-
- **Power Supply [PTE-001-12]**
 - Voltage input : 220VAC, 50Hz
 - Output voltage : +15VDC, 1A
+5VDC, 1A
-15VDC, 1A
-

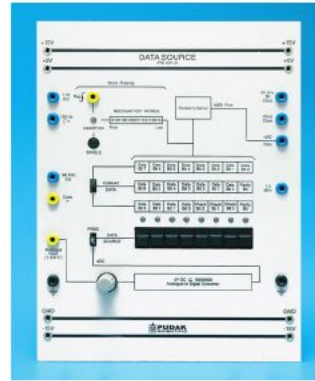

Data Source
PTE-001-01

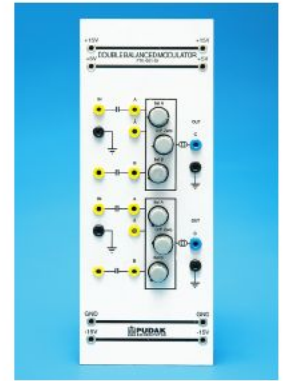

Double Balanced Modulator
PTE-001-02

PT 93229 Basic Digital Communication Trainer consists of

Cat. No.	Description	Qty.
PTE-001-01	Data Source	1 set
PTE-001-02	Double Balance Modulator	1 set
PTE-001-03	Data Clock Regeneration	1 set
PTE-001-04	Data Recovery	1 set
PTE-001-05	Data Receiver	1 set
PTE-001-06	Audio Module	2 set
PTE-001-07	Sigma Delta	1 set
PTE-001-08	Integrator	1 set
PTE-001-09	Sample Hold and Multiplexer	2 set
PTE-001-10	Tuned Circuit	1 set
PTE-001-11	Phase Locked Loop	1 set
PTE-001-12	Power Supply	1 set
FLS 20.02/097	Connecting Cross	40 pcs
KAL 99/40-030	Connecting Lead 30cm, Yellow	30 pcs
KAL 99/10-050	Connecting Lead 50cm, Black	10 pcs
KAL 99/20-050	Connecting Lead 50cm, Red	10 pcs
KAL 99/30-075	Connecting Lead 75cm, Blue	10 pcs
T03S-01E	Experiment Manual Book	1 pc
GSN 245	TPS Frame 1200mm	1 set

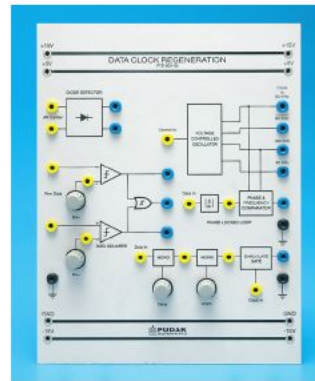

Data Clock Regeneration
PTE-001-03

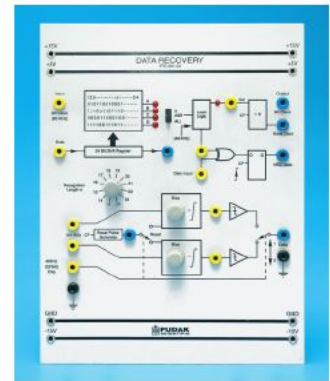

Data Recovery
PTE-001-04

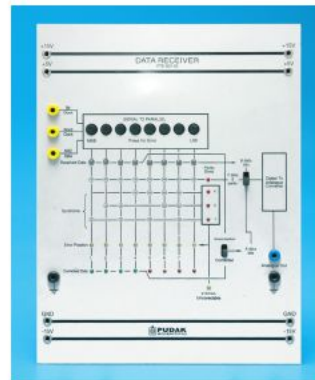

Data Receiver
PTE-001-05

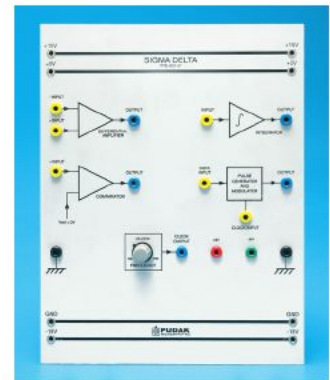

Sigma Delta
PTE-001-07

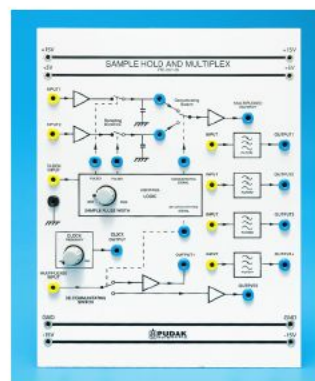

Sample Hold and Multiplexer
PTE-001-09

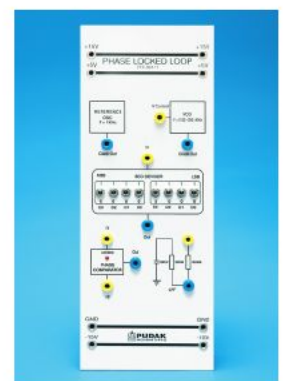

Phase Locked Loop
PTE-001-11

Specifications and illustrations are subject to change without prior notice

Features

- The Microwave trainer is a basic trainer which enables students to investigate the principles of microwave transmission systems such as those used in radar and communication links.
- The trainer is a bench top standard microwave system which is completely self-contained and use standard WR90/WG16 waveguide components to illustrate the essential elements of this field of study.
- The equipment comprises a set of waveguide components and a microwave console. The console contains the power supply for a modulated solid state X-band microwave source, a bridge type power measuring bolometer (thermistor type), and a meter which may be switched to monitor either as a detector output or as the supply current to the bridge.
- The experiment in microwave system provides a realistic practical work for student to carry out experiment, and it is suitable for courses ranging from technician studies to degree level.
- The whole system components are stored in the protective suite case.
- Complete with comprehensive Experiment manual book to guide student step by step in conducting experiments.

Covered Topics

- TE04001E Fundamental of Frequency and Wavelength
- TE04002E Measurement of Voltage Standing Wave Ratio (VSWR)
- TE04003E Measurement of Microwave Power
- TE04004E Detector Characteristics
- TE04005E Measurement of Impedance
- TE04006E Microwave Tuner
- TE04007E Directional Coupler
- TE04008E Series and Shunt Tee Coupler
- TE04009E Horn Antenna
- TE04010E Doppler Radar
- TE04011E Use of Coaxial cable

Microwave Trainer

PT 94124



Specification

- **Microwave Console [PTE-010-01]**
 - Supply voltage : AC 220V / 50Hz
 - Input/Output terminal type : BNC connector
 - Meter reads monitor for : - Detector Output
 - Bridge Current
 - Power Supply for a Modulated Solid state X-band Oscillator
 - Power measuring bolometer bridge
 - External Modulated Terminal (4mm) for X-band Oscillator
 - Amplifier Sensitivity for detector
- **Microwave Oscillator Components**
 - Band frequency : X-band
 - Frequency oscillation : 10.687GHz
 - Power output : 10mW (approx.)
- **Microwave System Components**
 - Standard type of waveguide : WR90 (USA) / WG16 (Europe)
 - Dimension of waveguide : 9.8 x 22.5 mm
 - Dimension of slotted line : Scaled in mm
 - Materials : Nickel plated brass
- **Microwave Trainer Suite Case [PTE-010-02]**
 - When not in use, the system components can be stored in the protective suite case
 - Dimension (W x L x H) : 18 x 64 x 45 cm

Training Panel System

PT 94124 Microwave Trainer consists of

Cat. No.	Description	Qty.
PTE-010-01	Microwave Console	1 unit
PTE-010-02	Microwave Trainer Suite Case	1 unit
PTE-010-A	Variable Attenuator	2 pcs
PTE-010-B	Slotted Line for use with Probe Detector	1 pc
PTE-010-C	Slotted Line Tuner	1 pc
PTE-010-D	Cavity Resonator	1 pc
PTE-010-E	Shunt Tee	1 pc
PTE-010-F	Directional Couple	1 pc
PTE-010-G	Series Tee	1 pc
PTE-010-H	Hybrid Tee	1 pc
PTE-010-J	Waveguide / Coaxial Adapter	2 pcs
PTE-010-K	Resistive Terminator	1 pc
PTE-010-L	Bolometer (Thermistor-type)	1 pc
PTE-010-M	Diode Detector (in Waveguide Section)	1 pc
PTE-010-N	Horn Antenna	2 pcs
PTE-010-P	X-Band Oscillator and Cable Assembly	1 pc
PTE-010-R	Short Circuit Terminator	2 pcs
PTE-010-S	Probe Detector	2 pcs
PTE-010-T	Coupling Plates	24 pcs
PTE-010-U	Support Plates	4 pcs
PTE-010-V	Thumb Nuts	48 pcs
GSC 230 06	N to N Connecting Lead	1 pc
GSC 230 04	BNC to BNC Connecting Lead	2 pcs
T04S-01E	Experiment Manual Book	1 pc

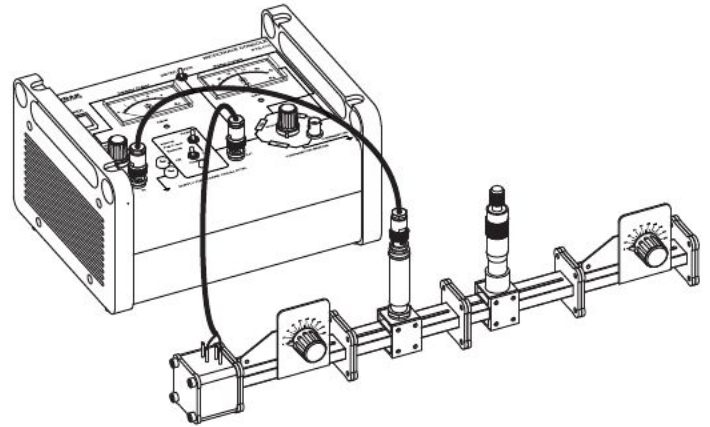

TE04006E | The Microwave Tuner

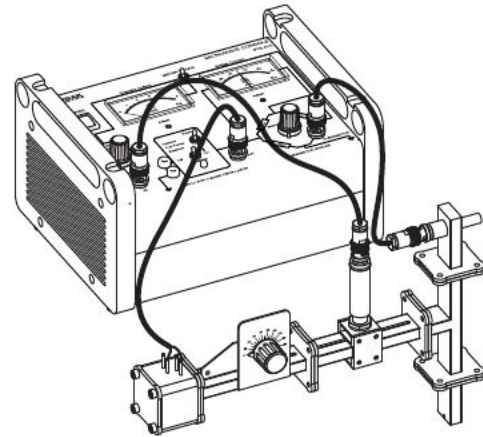

TE04008E | Series And Shunt Tee Coupling

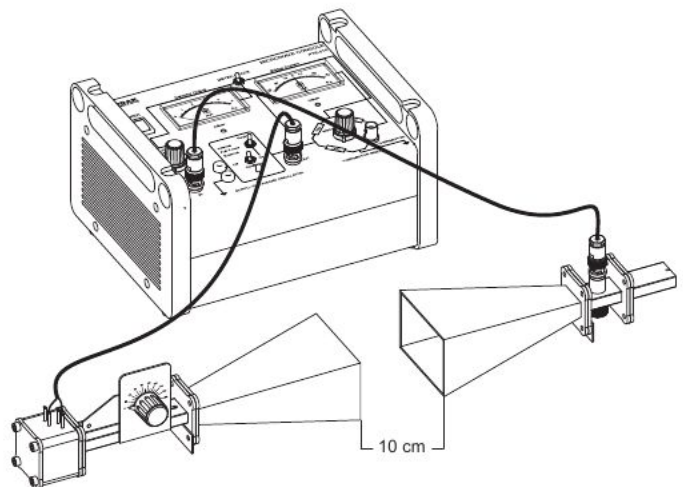

TE04010E | The Doppler Radar

Specifications and illustrations are subject to change without prior notice

Features

- The AM Transceiver Trainer is designed to teach and demonstrate the principles of AM transmissions and reception system.
- The trainer consist of modular block to enable the student to learn AM Transmitter and Receiver system in modular way. The panel type constructions are easy to handle by student when conducting the experiment.
- The trainer completed with fault simulator and fault indicator. The fault simulator can be used to teach troubleshooting.
- Completed with test point to show the wave form of AM signal system.
- All input and output on each panel are equipped with robust 4-mm sockets for easy connection.
- Complete with comprehensive Experiment manual book to guide the student step by step in conducting experiments.

AM Transceiver Trainer

PT 94329

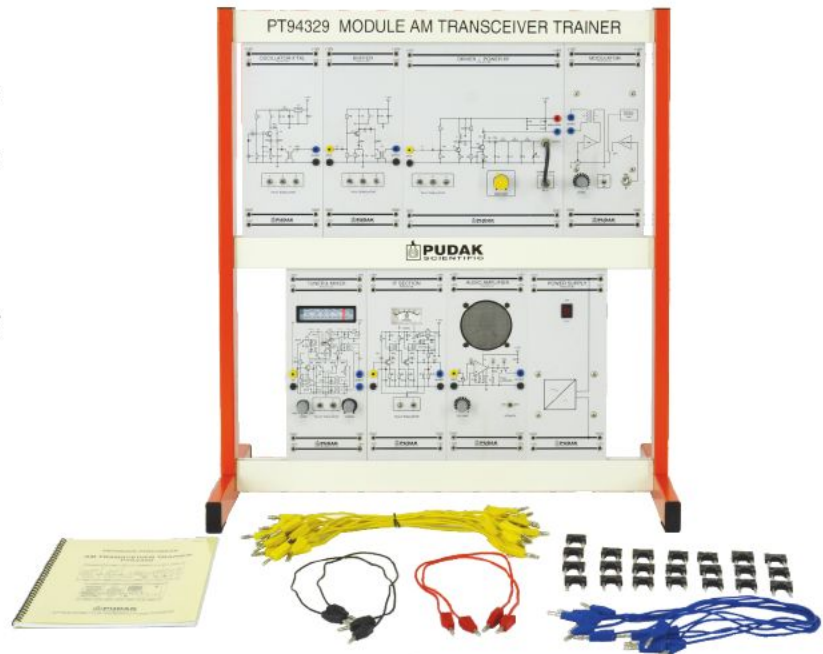

Covered Topics

- TE07001E Power Supply
- TE07002E X'tal Oscillator
- TE07003E Buffer
- TE07004E Driver/Power RF
- TE07005E Modulator
- TE07006E Tuner & Mixer
- TE07007E IF Section
- TE07008E Audio Amplifier

Specification

- **Power Supply [PTE-017-08]**
 - Input voltage : 220V, 50Hz
 - Output voltage : +15VDC, 2.5A
- **Receiver Section [PTE-017-05] ; [PTE-017-06]**
 - Frequency range : SW1 : 3 – 7 MHz;
SW2 : 7 – 12 MHz
 - Electrowave mode : AM / CW
 - IF frequency : 455kHz
 - Sensitivity : 2 μ V (approx.)
 - Input voltage : +15VDC
- **Transmitter Section [PTE-017-01] ; [PTE-017-02] ; [PTE-017-03] ; [PTE-017-04]**
 - Frequency : 3.579MHz (X'tal controlled oscillator)
 - RF power output : 5W (approx.)
 - Transmission mode : DSB
 - Output load : 50 Ω
 - Input voltage : 15VDC
- **Audio Amplifier [PTE-017-07]**
 - Input voltage : +15VDC
 - Power output : 2W (approx.)

Training Panel System

PT 94329 AM Transceiver Trainer consists of		
Cat. No.	Description	Qty.
PTE-017-01	X-Tal Oscillator	1 pc
PTE-017-02	Buffer	1 pc
PTE-017-03	Driver / Power RF	1 pc
PTE-017-04	Modulator	1 pc
PTE-017-05	Tuner & Mixer	1 pc
PTE-017-06	IF Section	1 pc
PTE-017-07	Audio Amplifier	1 pc
PTE-017-08	Power Supply	1 pc
FEL 220 01	Telescopic Antenna	1 pc
GSE 230 05	BNC to BNC Connecting Coaxial Cable	1 pc
FLS 20.02/097	Connecting Cross	30 pcs
KAL 99/40-050	Connecting Lead 50cm, Yellow	20 pcs
KAL 99/30-050	Connecting Lead 50cm, Blue	6 pcs
KAL 99/10-075	Connecting Lead 75cm, Black	2 pcs
KAL 99/20-075	Connecting Lead 75cm, Red	2 pcs
T07S-01E	Experiment Manual Book	1 pc
GSN 240	TPS Frame 600mm	1 set

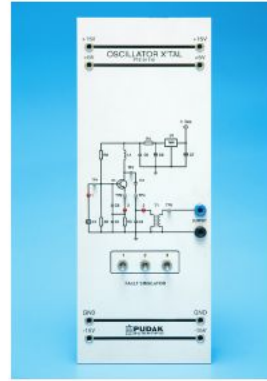

Oscillator X'TAL
PTE-017-01

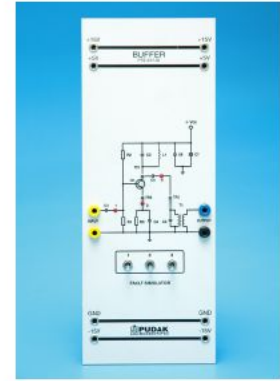

Buffer
PTE-017-02

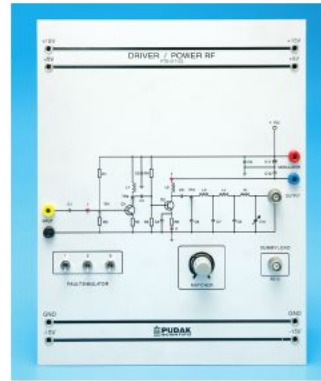

Driver / Power RF
PTE-017-03



Modulator
PTE-017-04



Tuner and Mixer
PTE-017-05



IF Section
PTE-017-06



Audio Amplifier
PTE-017-07



Power Supply
PTE-017-08

Specifications and illustrations are subject to change without prior notice

Features

- The FM Transceiver Trainer is designed to teach and demonstrate the principles of FM transmissions and reception system.
- The trainer consist of modular block to enable the student to learn FM Transmitter and Receiver system in modular way. The panel type constructions are easy to handle by student when conducting the experiment.
- Completed with test point to show the wave form of FM signal system.
- All input and output on each panel are equipped with robust 4-mm sockets for easy connection.
- Complete with comprehensive Experiment manual book to guide the student step by step in conducting experiments.

FM Transceiver Trainer

PT 94330



Covered Topics

- TE08001E Power Supply
- TE08002E Stereo MPX Encoder
- TE08003E Stereo FM Transmitter
- TE08004E Stereo FM Receiver
- TE08005E Audio Amplifier

Specification

- **Power Supply [PTE-018-06]**
 - Input voltage : 220V, 50Hz
 - Output voltage : +15VDC, 2.5A
- **Receiver Section [PTE-018-03]**
 - Frequency range : 88 – 108 MHz
 - IF frequency : 10.7MHz
 - Stereo MPX carrier : 38kHz
 - Stereo pilot : 19kHz
 - Sensitivity : 2 μ V (approx.)
 - Input voltage : +15VDC
- **Stereo Multiplexer section [PTE-018-01]**
 - Stereo sub carrier : 38kHz
 - Internal tone generator : 1kHz & 3kHz (switchable)
 - Input voltage : +15V
- **Transmitter Section [PTE-018-02]**
 - Frequency : 95MHz or 100MHz (switchable)
 - Frequency stabilization : PLL (Phase Lock Loop)
 - RF power output : 1W (approx.)
 - Output load : 50 Ω
 - Input voltage : +15V
- **Audio Amplifier [PTE-018-04]**
 - Input voltage : +15VDC
 - Power output : 2W (approx.)

Training Panel System

PT 94330 FM Transceiver Trainer consists of

Cat. No.	Description	Qty.
PTE-018-01	Stereo MPX Encoder	1 pc
PTE-018-02	FM Transmitter	1 pc
PTE-018-03	Stereo FM Receiver	1 pc
PTE-018-04	Audio Amplifier	1 pc
PTE-018-05	Speaker	2 pcs
PTE-018-06	Power Supply	1 pc
GSE 230 05	BNC to BNC Connecting Coaxial Cable	1 pc
FEL 220 01	Telescopic Antenna	1 pc
FLS 20.02/097	Connecting Cross	30 pcs
KAL 99/30-050	Connecting Lead 50cm, Yellow	20 pcs
KAL 99/10-075	Connecting Lead 50cm, Blue	6 pcs
KAL 99/10-075	Connecting Lead 75cm, Black	2 pcs
KAL 99/20-075	Connecting Lead 75cm, Red	2 pcs
T08S-01E	Experiment Manual Book	1 pc
GSN 240	TPS Frame 600mm	1 set

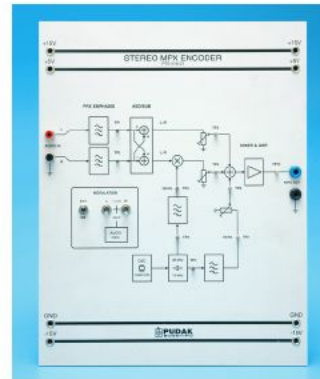

Stereo MPX Encoder
PTE-018-01



FM Transmitter
PTE-018-02



Stereo FM Receiver
PTE-018-03



Audio Amplifier
PTE-018-04



Speaker
PTE-018-05



Power Supply
PTE-018-06

Specifications and illustrations are subject to change without prior notice

Features

- The UHF Antenna System Demonstrator Trainer is designed as the teaching aid for studying electronic communication, especially for the antenna technology.
- The trainer can be used in teaching the fundamental, concepts theories, construction and demonstration of various operating antennas types.
- The trainer includes set of modular mechanical element that forming various antennas, a transmitter unit and a receiver unit.
- The trainer system is also equipped with the Antenna Control Unit for plotting the antenna radiation pattern manually or automatically.
- The Antenna Control Unit consists of a microcontroller based system for the antenna radiation pattern plotting, displaying, and printing.
- The system captures signal at a 9° rotation interval using by stepper motor, which is displayed on LCD panel and PC monitor.
- The Windows based Radiation Pattern Plotting Software is provided in CD.
- Equipped with a comprehensive experiment manual book to guide student step by step in conducting the experiments.

Covered Topics

The teaching level is for those whose concern is selecting, installing, commissioning and maintaining antennas.

Therefore the approach of the subject is non-mathematical and nonquantitative.

- TE06001 Operation of UHF Transmitter module
- TE06002 SWR and Power Meter
- TE06003 Stub Tuner Usage on the Transmitter Unit
- TE06004 Open Dipole Antenna, $\frac{1}{4}\lambda$ and $\frac{1}{2}\lambda$.
- TE06005 $\frac{1}{2}\lambda$ Vertical Antenna & $\frac{1}{4}\lambda$ Ground Plane Antenna
- TE06006 1λ Quad Loop Antenna
- TE06007 $\frac{1}{2}\lambda$ Slot Antenna
- TE06008 $\frac{1}{2}\lambda$ 4 elements Yagi Uda Antenna
- TE06009 Plotting Radiation Patterns of Directional & Omni Directional Antennas
- TE06010 Recording the Transmitter Strength Data on the RF Radiation Detector by Antenna Control Unit module

NEW PRODUCT

UHF Antenna System Demonstrator Trainer

PT 041227



Specification

- **Power Supply Unit [PTE05101]**
 - Supply voltage : 110 VAC / 220 VAC, 50 - 60 Hz (automatic mode)
 - Output Voltage : +15 VDC, +5 VDC and GND
 - Current : 2 A
- **UHF Transmitter [PTE05102]**
 - Input Voltage : +15 VDC
 - RF Transmitter : 425 - 470 MHz (output adjustable)
 - Output Power : 4 watt (max.)
 - Int. Modulator : 1 kHz
- **SWR and Power Meter [PTE05103]**
 - Range of Freq : 100 - 500 MHz
 - Power Meter : Forward and Reverse
 - Power Range : 5 W - 200 W (selectable)
- **Dummy Load [PTE05104]**
 - Output
 - Impedance : 50 Ohm
 - Power Max. : 15 watt
 - Frequency Max. : 500 MHz
- **Stub Tuner [PTE05105]**
 - Stub type : Slider
 - : Short Single Stub
- **Antenna Control Unit [PTE05106]**
 - Input Voltage : +15 VDC and +5 VDC
 - Control type : Micro controller ATMEGA16 based
 - Display : LCD 16x2 Alpha Numeric
 - Communication : Serial Port via USB
 - Output : Data link to PC
 - : Data link to Receiver
 - : Power to Antenna Receiver
 - Connector type : DIN connector 5 pin
 - : DIN connector 8 pin
 - Converter : USB to serial with FTDI

Continue >>

Training Panel System

>> Specification Continued

- **Antenna Transmitter with Rotator [PTE 05107]**
 - Input Voltage : +12 VDC (Regulated)
 - Rotation : 0 - 360°
 - Resolution : 9° per step
 - Input : RF Signal from UHF Transmitter module
 - Output : Data to Antenna Control Unit module
 - Connector type : UHF - Male Connector for INPUT
DIN connector 5 pin for OUTPUT

- **Antenna Receiver / Radiation Detector [PTE05108]**
 - Input Voltage : +5 VDC (Regulated)
 - Receiver Ant : Dipole 1/2λ
 - Detector display : Lamp
 - Connector type : DIN connector 8 pin

- **Accessories**
 1. Antennas
 - Dipole 1/4λ with balun
 - Dipole 1/2λ with balun
 - Vertical Antenna 1/2λ
 - Ground plane Antenna 1/4λ
 - Slot Antenna 1/2λ with balun
 - Quad Loop Antenna 1λ with balun
 - Yagi UDA Dipole 4 elements, 1/2λ with balun
 2. Connector
 - Coaxial cable RG-58A/U with UHF to UHF Connector (50 cm)
 - Coaxial cable RG-58A/U with UHF to UHF Connector (120 cm)
 - Coaxial cable RG-58A/U with BNC to UHF Connector (20 cm)
 - Cable 5 wire with DIN to DIN connector 5 pin (150 cm)
 - Connecting lead, 50 cm, Red
 - Connecting lead, 50 cm, Black
 - Connecting cross
 - UHF Female to Male Connector Adapter type L
 - USB to USB cable data
 3. Software
 - Radiation Pattern Plotting Software for Windows (XP, Vista, Windows7 and Windows8)
 4. Manual Experiments book in English & Bahasa
 5. Wooden box storage for antennas and accessories.
Dimension (W x L x H): 56 x 36 x 30 cm

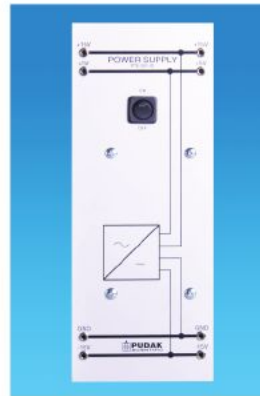

Power Supply
PTE-051-01



UHF Transmitter
PTE-051-02



SWR & Power Meter
PTE-051-03



Dummy Load
PTE-051-04



Stub Tuner
PTE-051-05



Antenna Control Unit
PTE-051-06

PT 041227 UHF Antenna System Demonstrator Trainer consist of		
Cat. No.	Description	Qty.
PTE-051-01	Power Supply	1 pc
PTE-051-02	UHF Transmitter	1 pc
PTE-051-03	SWR & Power Meter	1 pc
PTE-051-04	Dummy Load	1 pc
PTE-051-05	Stub Tuner	1 pc
PTE-051-06	Antenna Control Unit	1 pc
PTE-051-07	Antenna Transmitter with Rotator	1 pc
PTE-051-08	Antenna Receiver/ Radiation Detector	1 pc
ANT-051-01	Yagi UDA Dipole 4 elements 1/2λ Antenna	1 pc
ANT-051-02	Groundplane 1/4λ Antenna	1 pc
ANT-051-03	Quad Loop 1λ Antenna	1 pc
ANT-051-04	Dipole 1/2λ Antenna	1 pc
ANT-051-05	Dipole 1/4λ Antenna	1 pc
ANT-051-06	Vertical 1/2λ Antenna	1 pc
ANT-051-07	Slot 1/2λ Antenna	1 pc
GSE 232 06	Coaxial cable with UHF to UHF Connector 50 cm	1 pc
GSE 232 07	Coaxial cable with UHF to UHF Connector 120 cm	1 pc
GSE 232 03	Coaxial cable with BNC to UHF Connector 20 cm	1 pc
GSE 234 01	Cable 5 wire with DIN Male to Female 150cm	2 pcs
KAL 99/20-050	Connecting lead, 50cm, Red	2 pcs
KAL 99/10-050	Connecting lead, 50cm, Black	2 pcs
FLS/20.02/097	Connecting cross	20 pcs

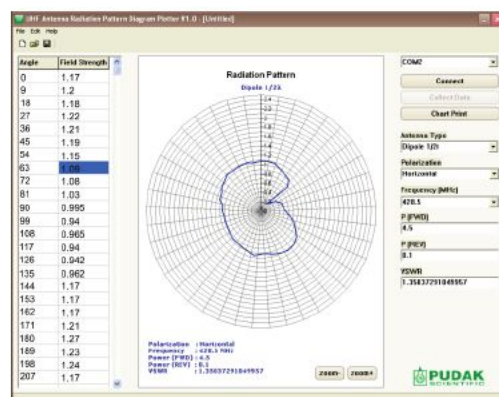

UHF Antenna Radiation Pattern Diagram Plotter

Specifications and illustrations are subject to change without prior notice

Features

- The trainer is designed for presentation and to practice the principles of basic electronics that covers; characteristic of electronic component, regulation, stabilization and protection of power supply, applied component in circuits, op-amp and filter circuits.
- Complete with assembly board that can be used to assemble the circuit with available discrete module's likes resistors, capacitors, transistors, etc. The connecting cross and connecting lead are used to connect the circuit to power supply.
- The system consist of modular block that enable the student to learn the basic electronic in modular way. The panel type constructions are easy to handle by student when conducting the experiment.
- All inputs and outputs on each panel are equipped with robust 4-mm sockets for easy connection.
- Connecting leads, connecting cross and other connecting device are supplied in sufficient quantity to do all experiments.
- Complete with comprehensive Experiment manual book to guide the student step by step in conducting experiments.

Basic Electronic Trainer

PT 93120

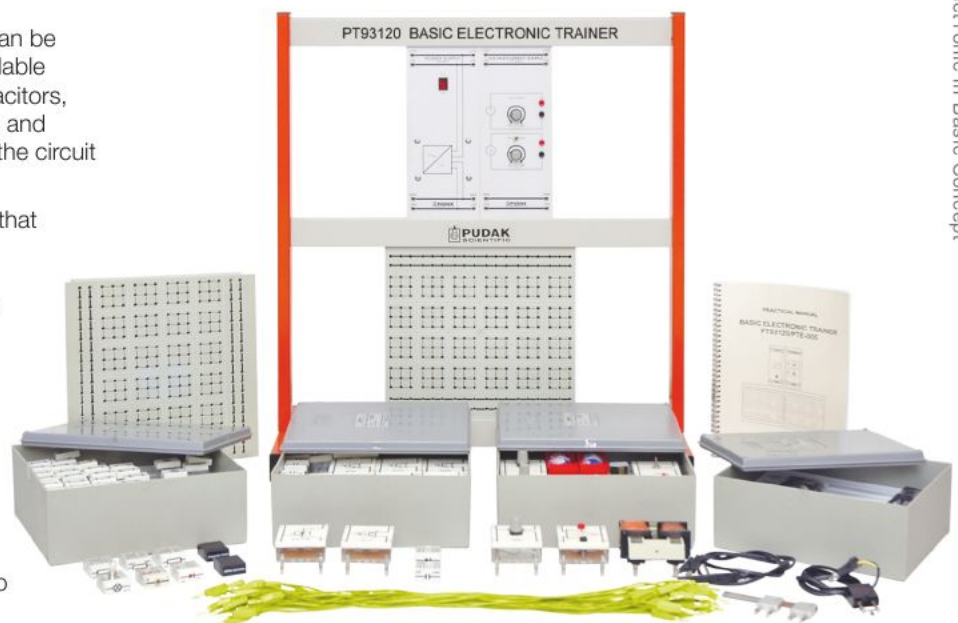

Covered Topics

- | | | | |
|-----------|---|-----------|--|
| ■ EE02001 | Introduction to Electronics | ■ EE02023 | Response of Integrator and Differentiator Circuits on Triangle Waves |
| ■ EE02002 | Ohm's Law | ■ EE02024 | Common Emitter Transistor Amplifier |
| ■ EE02003 | Thevenin's Theorem 1 | ■ EE02025 | Common Collector Transistor Amplifier |
| ■ EE02004 | Thevenin's Theorem 2 | ■ EE02026 | Transistor as a Switch |
| ■ EE02005 | The Theorem of Superposition | ■ EE02027 | Schmitt Trigger |
| ■ EE02006 | Series Coupled Resistance and Voltage Divider | ■ EE02028 | Mono Stable Multivibrator |
| ■ EE02007 | Parallel Coupled Resistance and Current Divider | ■ EE02029 | Bistable Multivibrator |
| ■ EE02008 | Wheatstone Bridge | ■ EE02030 | Astable Multivibrator |
| ■ EE02009 | Non-linear Resistance | ■ EE02031 | RC Coupled Amplifier |
| ■ EE02010 | Capacitors and Resistors Coupled in Series | ■ EE02032 | Direct Coupled Amplifier |
| ■ EE02011 | AC Signals | ■ EE02033 | Direct Coupled with Complementary Transistor |
| ■ EE02012 | The Influences of AC Signals on Resistors | ■ EE02034 | Common Source FET Amplifier |
| ■ EE02013 | The Influences of AC Signals on Coils | ■ EE02035 | Common Drain FET Amplifier |
| ■ EE02014 | The Influences of AC Signals on Capacitor | ■ EE02036 | Op-Amp as Voltage Follower |
| ■ EE02015 | Series Coupled RLC and Series Coupled Resonance | ■ EE02037 | Non-Inverting Op-Amp Amplifier |
| ■ EE02016 | Series Coupled Oscillator Circuit | ■ EE02038 | Inverting Op-Amp Amplifier |
| ■ EE02017 | The Influence of AC Signals on Parallel RC Circuits | ■ EE02039 | Uni-Junction Transistor |
| ■ EE02018 | The Influences of AC Signals on Parallel RL Circuits | ■ EE02040 | DIAC |
| ■ EE02019 | Parallel Coupled RLC and Parallel Resonance | ■ EE02041 | SCR and TRIAC |
| ■ EE02020 | Parallel Coupled Oscillator Circuits | ■ EE02042 | Half Wave Rectifier |
| ■ EE02021 | Filter | ■ EE02043 | Full Wave Rectifier |
| ■ EE02022 | Response of Integrator and Differentiator Circuit on Square Waves | ■ EE02044 | Power Control Using SCR |
| | | ■ EE02045 | Characteristic of Electrical Sources |
| | | ■ EE02046 | Current Sources Employing FET |
| | | ■ EE02047 | Current Sources Employing Bipolar Transistor |

Training Panel System

Specification

- Assembly Board for TPS Panel [GSE 110]**
 - Mountable to standard frame, used to assemble the experiment circuits from modular component
 - 24 socket grids with 24 conducting squares and 216 sockets
 - 6 socket grids with 36 sockets
 - 2 conducting paths with 18 sockets each.
 - Dimensions : 297 x 300 mm
- Power Supply [PTE-005-01]**
 - Output voltage : DC 5V / 1A ; 15V / 1A ; -15V / 1A
 - Input voltage : AC 220V, 1 phase 50Hz
 - Output connections : 4mm sockets
 - Dimension : 114 x 297 mm
- Voltage/Current Source [PTE-005-02]**
 - Voltage source : DC Variable 0 up to 12V / 250mA
 - Current source : 0 up to 500mA
 - Input voltage : 220V, 1 phase 50Hz
 - Output connections : 4mm sockets
 - Dimension : 114 x 297 mm
- Basic Meter [KAL-41]**
 - Amperemeter, range : 100uA — 100mA — 1A and 5A (DC)
 - Voltmeter, range : 100mV — 1V — 10V and 50V (DC)
- Section Boxes, consist of:**
 - Diode 1A, Diode Zener, DIAC, LED
 - Resistors, Potentiometers
 - Transistors, TRIAC, SCR, FET
 - LDR, NTC, PTC
 - Op-Amp
 - Toggle Switches
 - Capacitors
 - UI Core with 500 and 1000 Winding Coil



Power Supply
PTE-005-01



Voltage/Current Source
PTE-005-02

>>

Cat. No.	Description	Qty.
PEO 339 44	Resistor 1MΩ / 0.5W	1 pc
FLS 20.04/101	SPST Toggle Switch	2 pcs
PEO 102 02	Incandescent Lamp 3V + Lamp Holder E10	2 pcs
PEO 102 03	Incandescent Lamp 6V + Lamp Holder E10	2 pcs
PEO 102 04	Incandescent Lamp 12V + Lamp Holder E10	1 pc
FLS 20.07/103	Lamp Holder E10	3 pcs
FET 23.04	Neon Lamp	1 pc
PEL 222	Amperemeter Adapter	3 pcs
PEO 372 01	Red LED	1 pc
PEO 372 03	Green LED	1 pc
FLS 28.08/101	Potentiometer 1kΩ, 0.25W	2 pcs
PEO 322 03	Potentiometer 100kΩ, 0.25W	1 pc
PTE-005-04	Discreet Component Container - 2	1 set
FET 23.05	LDR	1 pc
PEO 411 02	Capacitor Non Polar 100nF	1 pc
PEO 411 03	Capacitor Non Polar 470nF	1 pc
PEO 412 01	Capacitor Tantalum 1μF/35V	1 pc
PEO 396 23	Capacitor Electrolyte 1μF/16V	1 pc
PEO 396 09	Capacitor Electrolyte 10μF/35V	5 pcs
PEO 396 10	Capacitor Electrolyte 100μF/35V	2 pcs
PEO 396 20	Capacitor Electrolyte 2200μF/35V	1 pc
FET 23.01	Diode 1N4002	4 pcs
PEO 360 11	Diode 1N60	1 pc
PEO 365 03	Diode Zener 5V, 0.25W	1 pc
PEO 370	DIAC DB3	1 pc
PEO 513	SCR C106	1 pc
PEO 511 01	TRIAC BT137D	1 pc
PEO 378 05	Transistor BC 547	3 pcs
PEO 378 04	Transistor BC 556	1 pc
PEO 382 01	FET SK-125	1 pc
PTE-005-05	Discreet Component Container - 3	1 set
FEM 21.00	U & I Core	1 pc
FEM 21.01/500	Coil 500 turns	1 pc
FEM 21.01/102	Coil 1000 turns	1 pc
PEO 512	UJT 2N246	1 pc
PEO 514	Operational Amplifier LM 741	1 pc
PEO 503 03	SPDT Toggle Switch	1 pc
PEO 503 02	DPDT Toggle Switch	1 pc
GSE 220	Battery Holder 1,5V	2 pcs
FLS 20.31/27	Battery 1,5V	2 pcs
GSE 220 04	Battery Holder 9V	1 pc
GSE 221 02	Battery 9V	1 pc
PTE-005-06	Discreet Component Container - 4	1 set
FLS 20.14/112	Bar Magnet	1 pc
FLS 20.13/111	Bimetal (set)	1 pc
PEO 500 01	NTC	1 set
PEO 500 02	PTC	1 set
FLS 20.02/097	Connecting Cross	40 pcs
KAL 99/40-030	Connecting Lead 30cm, Yellow	30 pcs
KAL 99/10-050	Connecting Lead 50cm, Black	10 pcs
KAL 99/20-050	Connecting Lead 50cm, Red	10 pcs
KAL 99/30-050	Connecting Lead 50cm, Blue	20 pcs
E02S-01E	Experiment manual Book	1 pc
GSN 240	TPS Frame 600mm	1 set

>>

Specifications and illustrations are subject to change without prior notice

PT 93120 Basic Electronic Trainer consists of		
Cat. No.	Description	Qty.
GSE 110	Assembly Board for TPS Panel	2 pcs
PTE-005-01	Power Supply	1 pc
PTE-005-02	Voltage/Current Source	1 pc
KAL-41	Basic Meter	2 pcs
PTE-005-03	Discreet Component Container - 1	1 set
PEO 339 01	Resistor 1Ω, 0.5W	1 pc
PEO 341 03	Resistor 3.3Ω, 2W	1 pc
PEO 339 03	Resistor 10Ω, 0.5W	2 pcs
PEO 339 05	Resistor 22Ω, 0.5W	1 pc
PEO 339 07	Resistor 47Ω, 0.5W	1 pc
PEO 339 08	Resistor 56Ω, 0.5W	1 pc
PEO 339 10	Resistor 100Ω, 0.5W	2 pcs
PEO 339 11	Resistor 150Ω, 0.5W	1 pc
PEO 344 01	Resistor 220Ω, 0.5 W	1 pc
PEO 339 13	Resistor 270Ω, 0.5W	1 pc
PEO 339 14	Resistor 330Ω, 0.5W	1 pc
PEO 339 15	Resistor 390Ω, 0.5W	1 pc
PEO 339 16	Resistor 470Ω, 0.5W	1 pc
PEO 339 17	Resistor 560Ω, 0.5W	1 pc
PEO 339 19	Resistor 1kΩ, 0.5W	4 pcs
PEO 339 20	Resistor 1,5kΩ, 0.5W	2 pcs
PEO 339 21	Resistor 2,2kΩ, 0.5W	1 pc
PEO 339 22	Resistor 3,3kΩ, 0.5W	1 pc
PEO 339 23	Resistor 4,7kΩ, 0.5W	2 pcs
PEO 339 24	Resistor 10kΩ, 0.5W	2 pcs
PEO 339 25	Resistor 12kΩ, 0.5W	1 pc
PEO 339 32	Resistor 47kΩ, 0.5W	1 pc
PEO 339 35	Resistor 82kΩ, 0.5W	1 pc
PEO 339 36	Resistor 100kΩ, 0.5W	2 pcs
PEO 339 42	Resistor 470kΩ, 0.5W	1 pc

Features

- The trainer is designed for general purpose training that offers ability to perform variation design of circuit and experiment function.
- The trainer provides jumper wires and a large size of breadboard for quick assembly of experiment circuit.
- Desktop type, easy to handle.
- Complete with power supply, function generator, voltmeter, amperemeter, speaker, buzzer and decade capacitors to support the experiment.
- All inputs and outputs are equipped with robust 4-mm sockets for easy connection.
- Connecting leads, connecting cross and other connecting device are supplied in sufficient quantity to do all experiments.
- Complete with comprehensive Experiment manual book to guide the student step by step in conducting experiments.
- The teacher and student can make their own experiments.



Specification

- **Desktop Module [PTE-013-01]**, equipped with:
 - Project board
 - Standard breadboard, mounted on desktop, used to assemble the experiments circuits from discrete component
 - Size: 175 x 134 x 8 mm
 - Power Supply
 - Output : +5VDC / 1A
Variable 0 – 60VDC / 500mA
30VAC / 250mA CT
 - Input : 220VAC, 1 phase 50Hz
 - Output connections: 4mm
 - Function Generator
 - Frequency : 100Hz – 10KHz
 - Decade Attenuation Control 10mV, 100mV and 1V
 - Sine Wave and Triangle Wave output
 - DC Voltmeter
 - Range : 0 – 30 V
 - DC Amperemeter
 - Range : 0 – 3 A
 - Decade capacitor : 0 – 99 nF
 - Speaker : 2¼", 8Ω, 0.5W
 - Buzzer : 12V
 - Switches are SPDT Toggle Switch, SPST Toggle Switch, Push-On
- **Container Box [PTE-013-02]**, consist of:
 - Diode 1A, ZD, LED
 - Resistors, Potentiometers
 - Transistors
 - Op-Amp
 - Capacitors
 - Inductors

Covered Topics

- EE03001 Transistor as a Switch
- EE03002 Schmitt Trigger
- EE03003 Op-Amp as Voltage Follower
- EE03004 Non-Inverting Op-Amp Amplifier
- EE03005 Inverting Op-Amp Amplifier
- EE03006 Mono Stable Multivibrator
- EE03007 Bistable Multivibrator
- EE03008 Astable Multivibrator

Training Panel System

PT 93132 Laboratory Breadboard
 consists of

Cat. No.	Description	Qty.
PTE-013-01	Desktop Module	1 set
PTE-013-02	Container Box, consist of:	1 set
PEO 394 01	Capacitor 1nF Non Polar	2 pcs
PEO 394 02	Capacitor 2.2nF Non Polar	2 pcs
PEO 394 03	Capacitor 4.7nF Non Polar	2 pcs
PEO 394 04	Capacitor 6.8nF Non Polar	2 pcs
PEO 394 05	Capacitor 10nF Non Polar	2 pcs
PEO 394 06	Capacitor 22nF Non Polar	2 pcs
PEO 394 07	Capacitor 47nF Non Polar	2 pcs
PEO 394 08	Capacitor 68nF Non Polar	2 pcs
PEO 394 09	Capacitor 100nF Non Polar	2 pcs
PEO 394 10	Capacitor 220nF Non Polar	2 pcs
PEO 394 11	Capacitor 470nF Non Polar	2 pcs
PEO 394 12	Capacitor 680nF Non Polar	2 pcs
PEO 390 01	Capacitor 1 μ F, 16V Electrolyte	2 pcs
PEO 390 02	Capacitor 2.2 μ F, 16V Electrolyte	2 pcs
PEO 390 03	Capacitor 4.7 μ F, 16V Electrolyte	1 pc
PEO 390 05	Capacitor 10 μ F, 16V Electrolyte	2 pcs
PEO 390 08	Capacitor 22 μ F, 16V Electrolyte	2 pcs
PEO 390 04	Capacitor 47 μ F, 16V Electrolyte	1 pc
PEO 390 09	Capacitor 100 μ F, 16V Electrolyte	2 pcs
PEO 390 10	Capacitor 220 μ F, 16V Electrolyte	2 pcs
PEO 390 11	Capacitor 470 μ F, 16V Electrolyte	1 pc
PEO 331 03	Resistor 10 Ω , 0.5 W	10 pcs
PEO 331 06	Resistor 33 Ω , 0.5 W	10 pcs
PEO 331 09	Resistor 68 Ω , 0.5 W	10 pcs
PEO 331 10	Resistor 82 Ω , 0.5 W	10 pcs
PEO 331 11	Resistor 100 Ω , 0.5 W	10 pcs
PEO 331 15	Resistor 330 Ω , 0.5 W	10 pcs
PEO 331 19	Resistor 680 Ω , 0.5 W	10 pcs
PEO 331 20	Resistor 820 Ω , 0.5 W	10 pcs
PEO 331 21	Resistor 1k Ω , 0.5 W	10 pcs
PEO 331 24	Resistor 3.3k Ω , 0.5 W	10 pcs
PEO 331 26	Resistor 6.8k Ω , 0.5 W	10 pcs
PEO 331 27	Resistor 8.2k Ω , 0.5 W	10 pcs
PEO 331 28	Resistor 10k Ω , 0.5 W	5 pcs
PEO 331 34	Resistor 33k Ω , 0.5 W	5 pcs
PEO 331 38	Resistor 68k Ω , 0.5 W	5 pcs
PEO 331 39	Resistor 82k Ω , 0.5 W	5 pcs
PEO 331 40	Resistor 100k Ω , 0.5 W	5 pcs
PEO 331 44	Resistor 330k Ω , 0.5 W	5 pcs
PEO 331 47	Resistor 680k Ω , 0.5 W	5 pcs
PEO 331 48	Resistor 820k Ω , 0.5 W	5 pcs
PEO 331 49	Resistor 1M Ω , 0.5 W	5 pcs
FLS 20.08/101	Variable Resistor 1k Ω	2 pcs
FLA 20.08/103	Variable Resistor 10k Ω	2 pcs
PEO 322 03	Variable Resistor 100k Ω	2 pcs
PEO 361 03	Diode 1N4002	5 pcs
PEO 361 09	Diode 1N4148	5 pcs
PEO 361 11	Diode 1N60	2 pcs
PEO 373 01	LED 5mm, Red	4 pcs
PEO 377 02	Transistor BC 108	3 pcs
PEO 380 01	Transistor C 9012	3 pcs
PEO 380 02	Transistor C 9014	3 pcs
PEO 380 03	Transistor TIP 42C	1 pc
PEO 380 04	Transistor TIP 41	1 pc
PEO 514 01	Operational Amplifier UA 741	2 pcs
PEO 514 02	IC Timer LM 555	1 pc
PEO 180 01	Single Core Cable \varnothing 1mm, Red	5 m
PEO 180 02	Single Core Cable \varnothing 1mm, Black	5 m
GSE 234 01	Connecting Lead 20 cm, Red	30 cm
GSE 234 02	Connecting Lead 20 cm, Blue	30 cm
GSE 234 03	Connecting Lead 20 cm, Yellow	30 cm
GSE 234 04	Connecting Lead 20 cm, Black	30 cm
E03S-01	Experiment Manual Book	1 pc

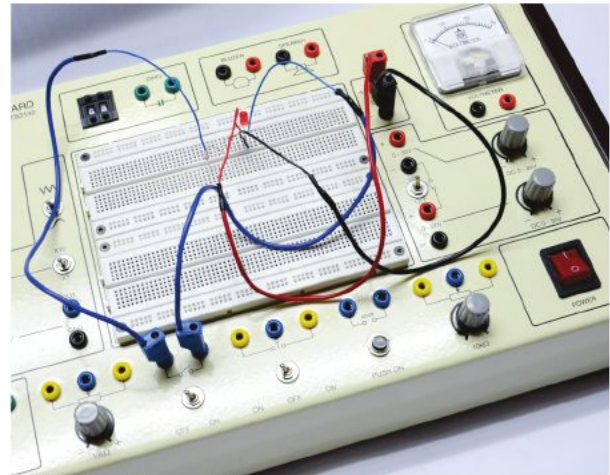

EE03001 | Transistor as a Switch

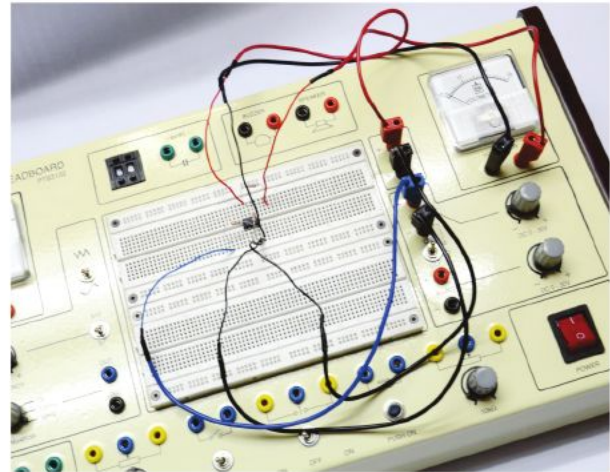

EE03004 | Op-Amp as Voltage Follower

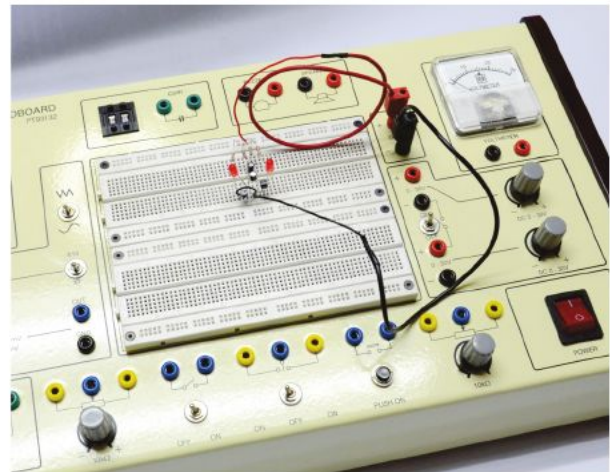

EE03008 | Astable Multivibrator

Specifications and illustrations are subject to change without prior notice

Features

- The trainer is designed for presentation and to practices the principles of basic electronic applications that covers; regulation, stabilization and protection of power supply, applied component in circuits and op-amp circuit.
- Completed with assembly board, that can be used to assemble the circuit with available discrete module's likes resistors, capacitors, transistors, etc. The connecting cross and connecting lead are used to connect the circuit to power supply.
- The system consist of modular block that enable the student to learn the basic electronic in modular way. The panel type constructions are easy to handle by student when conducting the experiment.
- All inputs and outputs on each panel are equipped with robust 4-mm sockets for easy connection.
- Connecting leads, connecting cross and other connecting device are supplied in sufficient quantity to do all experiments.
- Complete with comprehensive Experiment manual book to guide the student step by step in conducting experiments.

Circuit Application Trainer

PT 94123

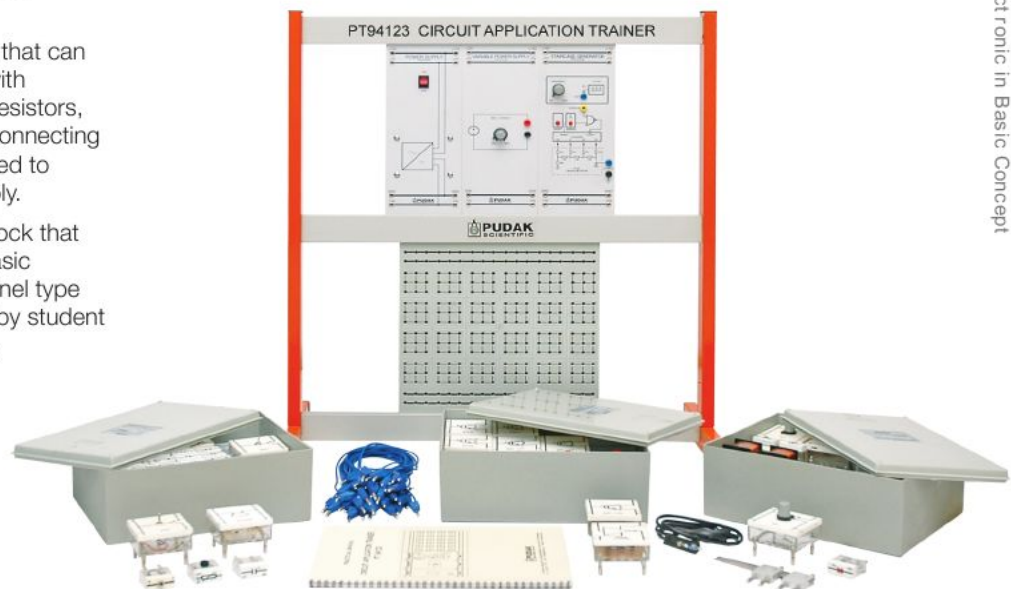

Specification

Covered Topics

- EE05001 Common Emitter Transistor Amplifier
- EE05002 Common Collector Transistor Amplifier
- EE05003 Complementary Push Pull Amplifier
- EE05004 Differential Transistor Amplifier
- EE05005 Op-Amp as Voltage Follower
- EE05006 Op-Amp as Comparator
- EE05007 Op-Amp as Integrator
- EE05008 Transistor as a Switch
- EE05009 Astable Multivibrator
- EE05010 Phase Shift Oscillator
- EE05011 Triangle Wave Generator
- EE05012 UJT Pulse Generator
- EE05013 Bistable Multivibrator
- EE05014 Staircase Generator
- EE05015 Light Operated Alarm
- EE05016 Delay Circuit
- EE05017 Temperature Operated Switch
- EE05018 Schmitt Trigger
- EE05019 Light Operated Flasher
- EE05020 Voltage Regulator

- **Assembly Board for TPS Panel [GSE 110]**
 - Mountable to standard frame, used to assemble the experiments circuits from modular component
 - 24 socket grids with 24 conducting squares and 216 sockets
 - 6 socket grids with 36 sockets
 - 2 conducting paths with 18 sockets
 - Each dimensions: 297 × 300 mm
- **Power Supply [PTE-015-01]**
 - Output voltage : DC 5V / 1A ; 15V / 1A ; -15V / 1A
 - Input voltage : AC 220V, 1 phase 50Hz
 - Output connections : 4mm sockets
 - Dimension : 114 × 297 mm
- **Power Supply Variable [PTE-015-02]**
 - Output voltage : DC Variable 0 up to 12V / 250mA
 - Input voltage : AC 220V, 1 phase 50Hz
 - Output connections : 4mm sockets
 - Dimension : 114 × 297 mm
- **Staircase Generator [PTE-015-03]**
 - Input voltage : +15 VDC, -15 VDC
 - Output connections : 4mm sockets
 - Dimension : 114 × 297 mm
- **Basic Meter [KAL-41]**
 - Amperemeter, range : 100 μ A – 100mA – 1A and 5A (DC)
 - Voltmeter, range : 100mV – 1V – 10V and 50V (DC)
- **Section Boxes, consist of:**
 - Diode bridge 1A, Diode 1A, ZD, DIAC, LED
 - Regulator
 - Resistors, Potentiometers
 - Transistors
 - Op-Amp
 - Switch Change-Over SPDT
 - Buzzer
 - Relay

Training Panel System

PT 94123 Circuit Application Trainer consists of

Cat. No.	Description	Qty.
GSE 110	Assembly Board for TPS Panel	1 pc
PTE-015-01	Power Supply	1 pc
PTE-015-02	Variable Power Supply	1 pc
PTE-015-03	Staircase Generator	1 pc
KAL-41	Basic Meter	1 pc
PTE-015-04	Container Box I, consists of:	1 set
PEO 339 10	Resistor 100 Ω , 0.5W	1 pc
PEO 339 15	Resistor 390 Ω , 0.5W	1 pc
PEO 339 16	Resistor 470 Ω , 0.5W	1 pc
PEO 339 19	Resistor 1k Ω , 0.5W	4 pcs
PEO 339 20	Resistor 1k5 Ω , 0.5W	1 pc
PEO 339 21	Resistor 2k2 Ω , 0.5W	1 pc
PEO 339 22	Resistor 3k3 Ω , 0.5W	3 pcs
PEO 339 23	Resistor 4k7 Ω , 0.5W	2 pcs
PEO 339 24	Resistor 10k Ω , 0.5W	2 pcs
PEO 339 32	Resistor 47k Ω , 0.5W	1 pc
PEO 339 33	Resistor 56k Ω , 0.5W	2 pcs
PEO 339 35	Resistor 82k Ω , 0.5W	1 pc
PEO 339 36	Resistor 100k Ω , 0.5W	3 pcs
PEO 339 37	Resistor 120k Ω , 0.5W	1 pc
PEO 339 38	Resistor 330k Ω , 0.5W	1 pc
PEO 339 42	Resistor 470k Ω , 0.5W	1 pc
FET 23.02 / 001	Capacitor Electrolyte 1 μ F, 35V	1 pc
PEO 396 09	Capacitor Electrolyte 10 μ F, 35V	3 pcs
PEO 396 10	Capacitor Electrolyte 100 μ F, 35V	1 pc
PEO 339 21	Capacitor Non Polar 10nF, 35V	3 pcs
PEO 396 22	Capacitor Non Polar 100nF, 35V	1 pc
FET 23.05	LDR	1 pc
PEO 516	Buzzer	1 pc
FET 23.01	Diode 1N4002	2 pcs
FLS 20.04/101	SPST Toggle Switch	2 pcs
PEO 310 01	SPDT Toggle Switch	2 pcs
PTE-015-05	Container Box II, consists of:	1 set
PEO 378 04	Transistor BC 546	2 pcs
PEO 378 05	Transistor BC 547	2 pcs
FET 23.03/139	Transistor BD 139	2 pcs
FET 23.03/140	Transistor BD 140	1 pc
PEO 514	Operational-Amplifier LM 741	2 pcs
PEO 517	Phase Inverter (LM741)	1 pc
PEO 515	Relay 6V	1 pc
PTE-015-06	Container Box III, consist of:	1 set
PEO 500 01	NTC	1 pc
FLS 20.08/11	Potentiometer 1k Ω	1 pc
PEO 322 04	Potentiometer 5k Ω	2 pcs
PEO 102 03	Incandescent Lamp 6V + Lamp Holder E10	1 pc
FEM 21.00	U & I Core	1 pc
PEO 372 03	LED, Green	1 pc
PEO 372 01	LED, Red	1 pc
PEO 512	UJT 2N2646	1 pc
FLS 20.02/097	Connecting Cross	40 pcs
KAL 99/40-030	Connecting Lead 30cm, Yellow	15 pcs
KAL 99/10-050	Connecting Lead 50cm, Black	10 pcs
KAL 99/20-050	Connecting Lead 50cm, Red	10 pcs
KAL 99/30-050	Connecting Lead 50cm, Blue	20 pcs
E05S-01E	Experiment Manual Book	1 pc
GSN 240	TPS Frame 600mm	1 set



Variable Power Supply
PTE-015-02

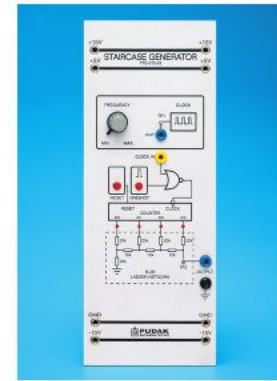

Staircase Generator
PTE-015-03



Container Box I
PTE-015-04

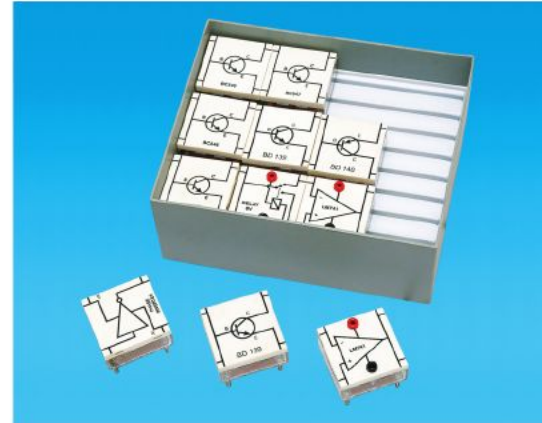

Container Box II
PTE-015-05



Container Box III
PTE-015-06

Specifications and illustrations are subject to change without prior notice

Features

- The trainer is designed to cover the fundamental concept, theory and application of operational amplifier with descriptive and easy to understand.
- The trainer supplied with power supplies required to run the experiments.
- Desktop type, easy to handle.
- All inputs and outputs on each panel equipped with robust 4-mm sockets easy connection.
- Connecting leads, connecting cross and other connecting device are supplied in sufficient quantity to do all experiments.
- Complete with comprehensive Experiment manual book to guide student step by step in conducting experiments.

Operational Amplifier Trainer

PT 970232



Covered Topics

- EE07001 Comparator
- EE07002 Inverting Amplifier
- EE07003 Voltage Gain in Inverting Amplifier
- EE07004 Frequency Dependence in Inverting Amplifier
- EE07005 Voltage Adders
- EE07006 Subtractors
- EE07007 Constant Voltage Source Adjustable
- EE07008 Constant Current Source
- EE07009 Non Inverting Amplifier
- EE07010 Voltage Follower
- EE07011 Differentiator
- EE07012 Integrator
- EE07013 Wien-Bridge Oscillator
- EE07014 High Pass Filter
- EE07015 Low Pass Filter

Specification

- **Desktop Module [PTE-023-01]**, equipped with:
 - Universal configuration of Operational Amplifier
 - Power Supply
 - Output : DC Fixed 3, 6, 9, 12V
 - Input : AC 220V, 1 phase 50Hz
 - Output connections : 4mm
 - Potentiometer 10kΩ and 50kΩ
- **Container Box [PTE-023-02]**, consists of:
 - Resistor 470Ω/1W
 - Resistor 1k5Ω/1W
 - Resistor 6k8Ω/1W
 - Resistor 8k2Ω/1W
 - Resistor 10kΩ/1W
 - Resistor 15kΩ/1W
 - Resistor 18kΩ/1W
 - Resistor 22kΩ/1W
 - Resistor 33kΩ/1W
 - Resistor 100kΩ/1W
 - Resistor 470kΩ/1W
 - Capacitor 1nF non polar
 - Capacitor 4,7nF non polar
 - Capacitor 10nF non polar
 - Capacitor 100nF non polar
 - Capacitor electrolyte 1μF/16V
 - Zener Diode 5,6V / 0,25W

Training Panel System

PT 970232 Operational Amplifier Trainer consists of

Cat. No.	Description	Qty.
PTE-023-01	Desktop Module, consists of:	1 set
PTE-023-02	Container Box, consists of:	1 set
PEO 340 15	Resistor 470Ω / 1W	1 pc
PEO 340 19	Resistor 1k5Ω / 1W	1 pc
PEO 340 23	Resistor 6k8Ω / 1W	1 pc
PEO 340 24	Resistor 8k2Ω / 1W	1 pc
PEO 340 25	Resistor 10kΩ / 1W	1 pc
PEO 340 26	Resistor 15kΩ / 1W	1 pc
PEO 340 27	Resistor 18kΩ / 1W	1 pc
PEO 340 28	Resistor 22kΩ / 1W	1 pc
PEO 340 29	Resistor 33kΩ / 1W	1 pc
PEO 340 35	Resistor 100kΩ / 1W	1 pc
PEO 340 41	Resistor 470kΩ / 1W	1 pc
PEO 411 04	Capacitor 1nF	1 pc
PEO 411 05	Capacitor 4,7nF	1 pc
PEO 411 01	Capacitor 10nF	1 pc
PEO 411 02	Capacitor 100nF	1 pc
PEO 395 08	Capacitor 1μF	1 pc
PEO 365 04	Zener Diode 5,6V / 0,25W	1 pc
FLS 20.02/097	Connecting Cross	10 pcs
KAL 99/40-030	Connecting Lead 30cm, Yellow	20 pcs
E07S-01E	Experiment Manual Book	1 pc

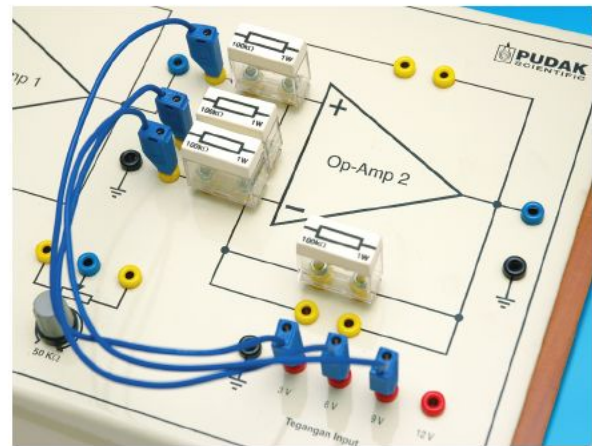

Experiment EE07005 Voltage Adders



Section Boxes

Features

- The digital trainer is designed as a teaching aid for digital technology.
- The trainer consists of several functional modules, such as basic gate, flip-flops, multiplexer, demultiplexer, registers, counters, adder, comparator, ADC, DAC, arithmetic logic unit and so on. All digital function symbols printed referring to standard IEEE logic symbols.
- All inputs and outputs terminal of digital function are equipped with LED indicator to indicate current state of inputs or outputs terminal.
- The modules are equipped with over-voltage and over current protector to protect module from damage possibility.
- The system consist of modular block to enable the student to learn the digital technology in modular way. The panel type constructions are easy to handle by student when conducting the experiment.
- All inputs and outputs on each panel are equipped with robust 4-mm sockets for easy connection.
- Complete with comprehensive experiment manual book to guide student step by step in conducting experiments.

Digital Trainer

PT 93131

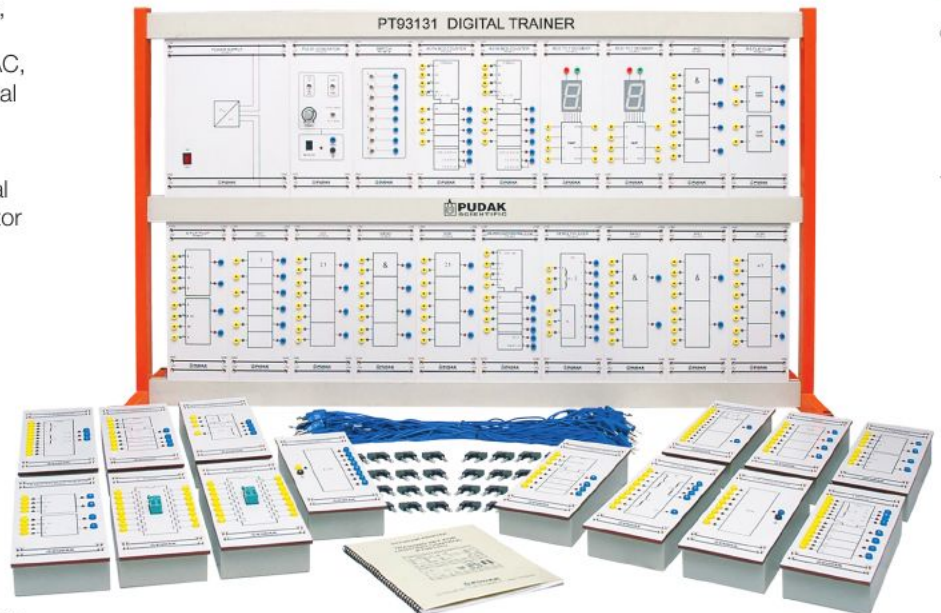

Covered Topics

- DE01001E Logic Gates
- DE01002E The Boolean Algebra
- DE01003E Combinational Logic
- DE01004E De Morgan's Law
- DE01005E Building Logic Circuit Based on A Truth Table
- DE01006E The Karnaugh Map
- DE01007E Adder and Arithmetic Circuits
- DE01008E Designing A Logic Circuits
- DE01009E Flip-Flop Circuits
- DE01010E Multi Vibrator
- DE01011E Counter
- DE01012E Shift Register
- DE01013E Decoder and Encoder
- DE01014E Analog to Digital Converter and Digital To Analog Converter
- DE01015E Multiplexer and Demultiplexer

Specification

- **AND Gate Dual Input [PTE-006-01]**
 - Supply voltage : +5VDC
 - Consist : 4 Gates/module
- **NAND Gate Dual Input [PTE-006-02]**
 - Supply voltage : +5VDC
 - Consist : 4 Gates/module
- **OR Gate Dual Input [PTE-006-03]**
 - Supply voltage : +5VDC
 - Consist : 4 Gates/module
- **NOR Gate Dual Input [PTE-006-04]**
 - Supply voltage : +5VDC
 - Consist : 4 Gates/module
- **XOR Gate Dual Input [PTE-006-05]**
 - Supply voltage : +5VDC
 - Consist : 4 Gates/module
- **XNOR Gate Dual Input [PTE-006-06]**
 - Supply voltage : +5VDC
 - Consist : 4 Gates/module
- **NAND Gate Quad Input [PTE-006-07]**
 - Supply voltage : +5VDC
 - Consist : 2 Gates/module
- **NOT Gate (Inverter) [PTE-006-08]**
 - Supply voltage : +5VDC
 - Consist : 6 Gates/module
- **AND Gate Quad Input [PTE-006-09]**
 - Supply voltage : +5VDC
 - Consist : 2 Gates/module
- **RS Flip-Flop [PTE-006-10]**
 - Supply voltage : +5VDC
 - Consist : 2 Flip-Flop/module
- **JK Master-Slave Flip-Flop [PTE-006-11]**
 - Supply voltage : +5VDC
 - Consist : 2 Flip-Flop/module

Continue >>

Training Panel System

>> Specification Continued

- **D Flip-Flop [PTE-006-12]**
 - Supply voltage : +5VDC
 - Consist : 2 Flip-Flop/module

- **Multiplexer 4 bit [PTE-006-13]**
 - Supply voltage : +5VDC
 - Consist : 2 Multiplexer/module

- **Demultiplexer 8 bit [PTE-006-14]**
 - Supply voltage : +5VDC
 - Package : 1 Demultiplexer/module

- **BCD to 7 Segments [PTE-006-15]**
 - Supply voltage : +5VDC, +15VDC
 - Consist : 1 BCD to 7 Segments/module

- **4 bit Shift Register [PTE-006-16]**
 - Supply voltage : +5VDC
 - Consist : 1 Register/module

- **Asynchronous Binary Counter [PTE-006-17]**
 - Supply voltage : +5VDC
 - Consist : 1 Counter/module

- **Asynchronous BCD Counter [PTE-006-18]**
 - Supply voltage : +5VDC
 - Consist : 1 Counter/module

- **Syn Up/Dn Counter with Parallel Load [PTE-006-19]**
 - Supply voltage : +5VDC
 - Consist : 1 Counter/module

- **Full Adder [PTE-006-20]**
 - Supply voltage : +5VDC
 - Consist : 1 Adder/module

>>

>>

- **Comparator [PTE-006-21]**
 - Supply voltage : +5VDC
 - Consist : 1 Comparator/module

- **4 bit ALU [PTE-006-22]**
 - Supply voltage : +5VDC
 - Consist : 4 bit ALU/module

- **Analog to Digital Converter [PTE-006-23]**
 - Supply voltage : +5VDC, +15VDC, -15VDC
 - Consist : 1 ADC/module

- **Digital to Analog Converter [PTE-006-24]**
 - Supply voltage : +5VDC, +15VDC, -15VDC
 - Consist : 1 DAC/module

- **Pulse Generator [PTE-006-25]**
 - Supply voltage : +5VDC
 - Consist : 1 package/module
 - Frequency outputs : 1 – 10 Hz or 10 – 100 Hz
 - Pulse output : continues or single
 - Direct output or invert output

- **IC Socket [PTE-006-26]**
 - 16 pin universal ZIP DIP socket

- **Power Supply [PTE-006-27]**
 - Supply voltage : 220V – 240VAC, 50Hz
 - Voltage output : +15V, -15VDC 1A and +5VDC, 4A

- **Switch [PTE-006-28]**
 - Contains 8 switches

PT 93131 Digital Trainer consists of		
Cat. No.	Description	Qty.
PTE-006-01	AND Gate (Dual Input)	1 pc
PTE-006-02	NAND Gate	1 pc
PTE-006-03	OR Gate	1 pc
PTE-006-04	NOR Gate	1 pc
PTE-006-05	XOR Gate	1 pc
PTE-006-06	XNOR Gate	1 pc
PTE-006-07	NAND Gate	1 pc
PTE-006-08	NOT Gate	1 pc
PTE-006-09	AND Gate (Quad Input)	1 pc
PTE-006-10	RS Flip-Flop	1 pc
PTE-006-11	JK Master-Slave Flip-Flop	1 pc
PTE-006-12	D Flip-Flop	2 pcs
PTE-006-13	Multiplexer 4 bit	1 pc
PTE-006-14	Demultiplexer 8 bit	1 pc
PTE-006-15	BCD to 7 Segment	2 pcs
PTE-006-16	4 bit Shift Register	2 pcs
PTE-006-17	Asynchronous Binary Counter	1 pc
PTE-006-18	Asynchronous BCD Counter	2 pcs
PTE-006-19	Syn Up/Dn Counter with Parallel Load	1 pc
PTE-006-20	Full Adder	1 pc
PTE-006-21	Comparator	1 pc
PTE-006-22	4 bit ALU	1 pc
PTE-006-23	Analog to Digital Converter	1 pc
PTE-006-24	Digital to Analog Converter	1 pc
PTE-006-25	Pulse Generator	1 pc
PTE-006-26	IC Socket	2 pcs
PTE-006-27	Power Supply	1 pc
PTE-006-28	Switch	1 pc
FLS 20.02/097	Connecting Cross	60 pcs
KAL 99/30-050	Connecting Lead 50cm, Blue	60 pcs
KAL 99/10-050	Connecting Lead 50cm, Black	10 pcs
KAL 99/20-050	Connecting Lead 50cm, Red	10 pcs
D01S-01E	Experiment Manual Book	1 pc
GSN 245	TPS Frame 1200mm	1 set

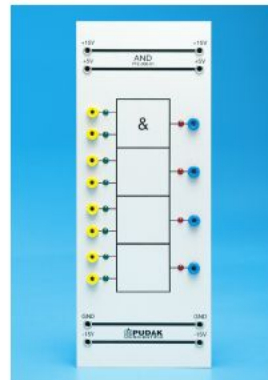

AND
PTE-006-01

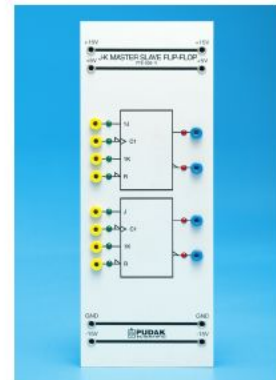

J-K Master Slave Flip-Flop
PTE-006-11

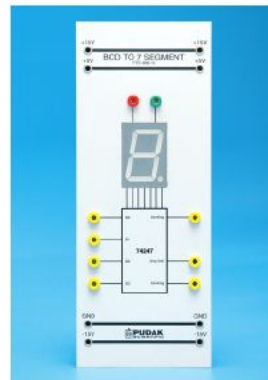

BCD to 7 Segment
PTE-006-16

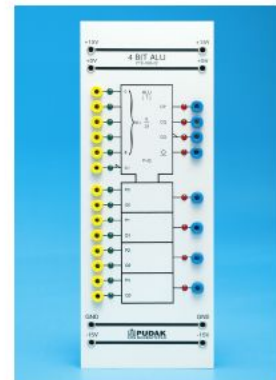

4 Bit ALU
PTE-006-22

Specifications and illustrations are subject to change without prior notice